



Brooklyn Council Go Kart Derby 2026 All Cub Scouts Welcome

Date: Saturday, May 16, 2026

Place: Marine Park Model Airplane Field
(Gerritsen Ave Between Seba & Lois Aves)

Time: 10:00 A.M. - Check-in

Opening Ceremony begins at 11:00 A.M.

Fee: \$8.00 per Cub Scout

Bring Your Own Kart or Use Ours

Attached is a Cub mobile diagram, building instructions and a parts list. It gives a basic design for the building of a go kart.

Also attached is the Brooklyn Council Go Kart Guidelines. Once the basic guidelines are followed you may build a go-kart however you like.

Must wear Helmet. Must wear seat belt

Must have a brake. Must be manually operated

Medals will be awarded to the 1st, 2nd 3rd place winning Packs

Deadline for online registration Thursday, May 14, 2026.

For further information or to volunteer to help, please contact: pack933bklyn@gmailcom

How to Build a Cubmobile

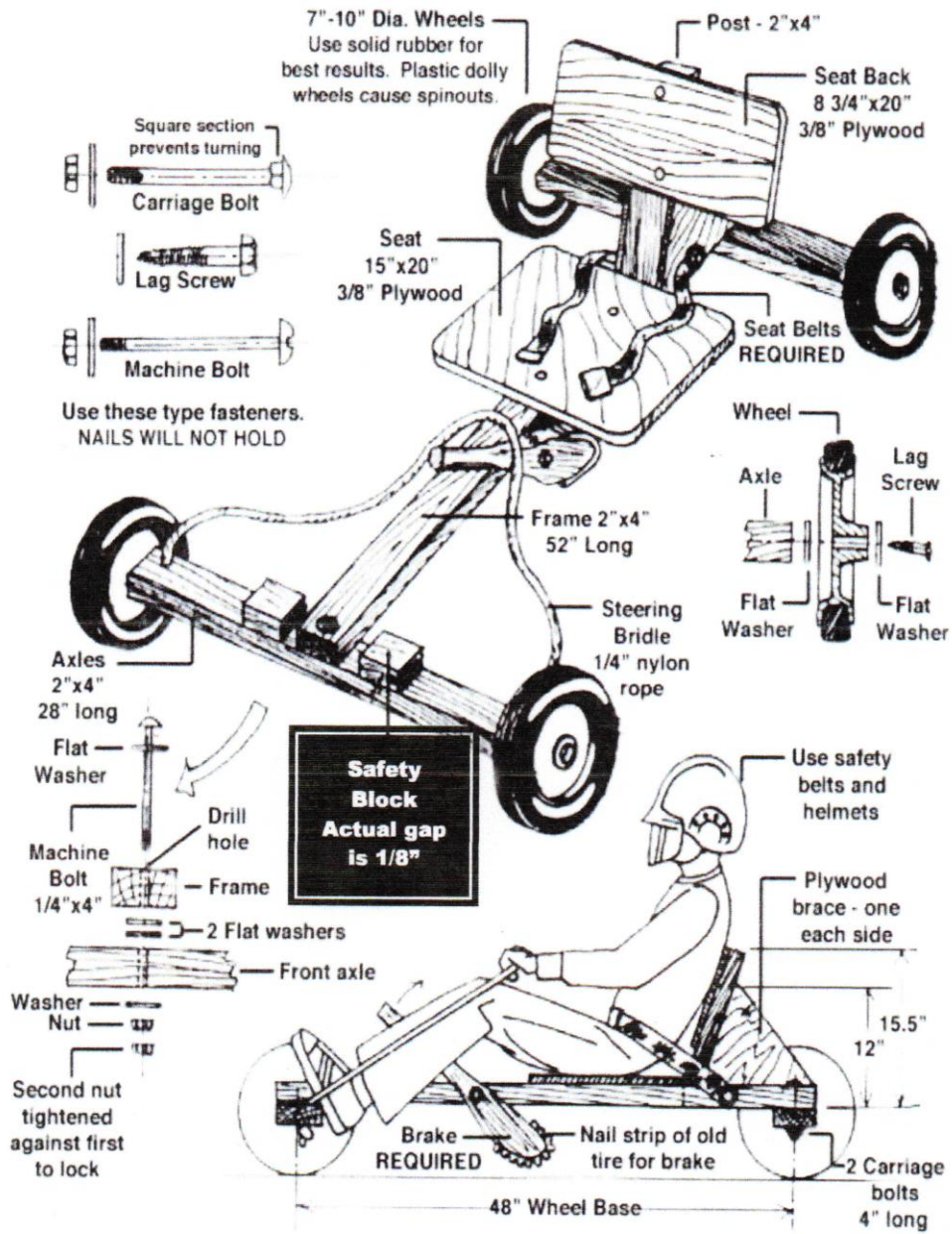

How To Build a Cub Mobile

Detailed Instructions:

1. Cut one 2 X 4 (up to) 60" for main frame.
2. Cut two 2 X 4's 28" for axles.
3. Make an "X" on each end of each axle, and drill a hole at each "X" intersect, 6" deep using a hand electric drill (5/16" wood bit works well).
4. On front axle 2X4:
 - a. Drill a 5/16" hole on each end near the back for the rope.
 - b. Drill a 3/8" hole at center of 2 X 4.
 - c. Attach (2) 2 X 4 safety blocks to front axle. The safety blocks must be attached to the front axle leaving only a 1/8" gap between the safety block and the main frame. The picture shows a much wider gap, but the narrow gap makes the cars much safer by limiting the range of steering.
5. At front of main frame 2X4, drill a 3/8" hole (center 1-5/8" from front).
6. Attach front axle to frame using 3/8" X 4" hex bolt, 4 washers, and lock nut or 2 nuts. (Tighten enough to allow steering).
7. Align back axle 2 X 4 at right angle with back of main frame 2X4, clamp if possible. Drill (2) 5/16" holes through axle and main frame. Attach main frame to back axle using 2 carriage bolts, 2 washers, 2 lock washers, and 2 nuts. If this is to be a permanent attachment, glue also.
8. Cut out seat and back rest from plywood.
9. Cut one 2 X 4 12-14" in length for back rest support. (Bevel slightly about 5 degrees if possible).
10. Attach backrest support (bevel end down) to mainframe using glue and 2 screws (#8...2 1/2") at an angle. Position of this support depends on size of boy, have scout sit on 2 X 4 frame to estimate position.
11. Cut out 2 triangular shaped pieces of plywood and attach to either side of

backrest support and main frame with glue and screws (#6 1-1/2"). Drilling small

pilot holes helps.

12. Attach seat and back rest using glue and screws (#6... 1-1/2").

13. Cut 2 X 2 surveyor's stake to 14-16" at an angle, cover end with rubber using

nails, drill a 3/8" hole through stake at location it will meet main frame.

14. Drill hole 5/16" into main frame at point to attach brake. Mount brake using 3/8" X

4" lag screw and washer to side of main frame.

15. Drill and attach seat belt with fasteners of choice.

16. Attach 6-7' of 1/4" rope to front axle as shown.

17. Attach wheels using washers and 3/8" X 6" lag screws. (Socket wrench helps).

18. Design & attach a push bar to the main frame of the vehicle.

Supplies & Tools

Quantity/ Description: Tools needed:

- 4 (up to) 10" wheels Power drill
- 1 2'X4' 3/8" or 1/2" plywood 3/8" and 5/16" wood bit
- 2 8" 2X4's Wrenches or socket set
- 1 2" X 2" surveyor's stake Screwdriver
- 4 3/8" X 6" lag screws (for wheels) Tape measurer
- 1 3/8" X 4" hex bolt (for front axle) Wood glue
- 1 3/8" X 4" lag screw (for brake) Power or hand saw
- 2 5/16" X 4" carnage bolts (for rear axle)
- 13 3/8" washers
- 1 3/8" lock nut
- 2 5/16" washers
- 2 5/16" lock washers
- 2 5/16" nuts
- 32 #6X1 1/2" wood screws
- 4 #6 X 2" wood screws
- 1 6-7' 1/4" rope
- 1 seat belt (from salvage yard)
- 1 2" X 6" piece of rubber (from old tire)

Brooklyn Council **Go Kart Guidelines**

- Wheels must not exceed 10 inches in diameter.
- All wheels may only be equipped with solid rubber tires.
- Car frame is made from 2-by-4-inch construction lumber.
- The overall length of the car is a maximum of 5 feet (60"); the wheel base a maximum of 4 feet (48").
- Front & rear axle no wider than 28".
- Use roundhead 1/4-inch bolts to hold frame. Screws are a second choice. Nails are not suitable, because they may work loose.
- All cars must have a seat with braced backrest, so the Scout can comfortably steer with his feet. A pre-fabricated seat may be used.
- Steering is done with the feet, which are placed on the front axle, and by the hands holding a rope fastened to the front axle.
- If threaded axles are used, the nuts must be secured with cotter pins or wire.
- Cars must be equipped with an adequate safety belt securely fastened to the main frame of the car.
- Cars must be equipped with a handbrake with its rubbing surface faced with a rubber material such as a strip of an old tire. This will stop the car when dragged on the ground.
- Car must be equipped with a push bar securely fastened to the main frame of the car so that one scout may push another down the course.
- During a race, the two 2-by-4-inch blocks fastened 1/4 to 1/2 inch from the center board will limit the turning radius. (Very important to test this before the race!)
- No extra weights, etc. may be placed on the Cubmobile.
- For the Scout's safety, they should wear long pants, a long sleeve shirt, and shoes that completely cover the feet, and a bike helmet.