

The Blue Mountain Council Annual Graf-Goranson

KLONDIKE DERBY

Guide Book



There are strange things done in the midnight sun by the men who moil for gold...

**Three rivers, Pioneer, and Eastern Oregon Districts
at ANDIES PRAIRIE SNO-PARK in the Umatilla National Forest**

A Note from the organizer

Hello all! My name is Bill Merk and I am with Troop 159 in Pasco as well as an eagle scout and alumni of troop 159. I've been participating in Klondike since I was in diapers so it's safe to say I enjoy winter camp and have the victory hats to go along with that. When I took charge of organizing the Klondike Derby, I made it my goal to give the boys the same exciting and fun experience I had when I was a youth participant. So, here's my offer to you. If you have ANY questions regarding the contents of this packet or anything involving klondike for that matter, feel free to email me. If you would like to organize a zoom meeting where I can give a training on klondike I would be more than happy to do so. I'm so excited to get up in the snow with everyone and look forward to seeing you all.

-Bill Merk

THIS YEAR'S DATES: FEBRUARY 21st AND 22nd 2025

KLONDIKE RULES & REGULATIONS

Next page please for more details.

Instructions

Sign up for a Klondike assigned patrol name on the registration form at the Scout Office. If you do not have a pre-assigned Klondike name, your patrol cannot be scored. The forms are made up in advance and NO ADD-ONS can be handled.

You will be asked to pay \$10.00 per Scout at this time. Please pay at the office when you sign up.

Each vehicle is required to have an Oregon Sno Park Pass to park at Andies Prairie. You can buy them in the Tri-Cities at various outdoor stores or at any Oregon DMV. Some may be available at the general store in Tollgate or at the Spout Springs Ski area. However, this is dependent on these establishments being open as they are not always open and running at the time of Klondike.

REQUIREMENTS for participation:

- Select a patrol name from the registration list at the Scout Service Center when you sign up. **Natural Patrols** are encouraged to develop Patrol teamwork.
- Please pay at the Council office ahead of time or at the time of registration using a credit card online. \$10.00 per youth.
- Prepare a patrol flag.
- Build your sledge or prepare/ repair an existing one.
- Build the strong box.
- Read the handout very carefully. (Only very close reading of the handout will put your patrol in the winner's circle.)
- Train your Scouts.
- Practice for the Klondike.
- File a tour plan if required.
- Have a winter camp trained Scouter along that has been trained within the last 5 yrs.
- Buy Snow-Park Permits for all of your vehicles. If you do not have one, you could be fined.
- Each member should have the 10 essentials with him. (Page 264, Centennial Scout Handbook; Page 268, 2022 BSA Handbook).

FOR ANY ADDITIONAL DETAILS, **Bill Merk (509)-366-3055 or Email – wemerk@hotmail.com**

Please note: We need thirty adults to help with judging the events during the competition. Check in with headquarters when you sign in. If you prefer to follow your patrol do not offer assistance during events, they participate in. Points will be subtracted by the event judge. This is the Scout's event, and we want it to be fair to all the patrols. Thank you for your leadership in teaching good sportsmanship!

KLONDIKE DERBY SCHEDULE

FRIDAY afternoon and early evening.

Arrive at the Klondike Derby site at the Andes Prairie Snow Park. Make sure that your Troop's vehicles are parked as close together as possible so that on Saturday there is room for others. Two vehicles should be parked nose to tail in the middle of the parking lot.

Patrols should present themselves to the Klondike Headquarters for inspection to ensure that they are prepared to stay overnight. Up to fifty points for passing the inspection. Each patrol member should be dressed appropriately and should have the minimum pack list shown below and be able to display all the items.

Choose a camping site away from the edge of the parking lot carefully so that you are not awakened at 3 AM when the snow blower hurls chunks of hard snow onto your site.

FRIDAY Evening

9:00PM Cracker Barrel

Scoutmasters and Senior Patrol Leaders meeting at Klondike Derby Headquarters in the parking lot.

SATURDAY

7-8 AM Cook Breakfast and Clean Campsite

Prepare for events

8:15 AM

Patrol Leaders report to Headquarters to pick up their scorecard. **Do not be late.**

Adult volunteers report to headquarters to pick up event gear and proceed to the event location and set up for the Klondike. **It requires at least 30 adults to man the Klondike events and serve as judges during the morning. It will be appreciated if ALL adults participate in this activity.**

8:30 AM

Sledge and patrol flag judging. All patrols line up opposite the Klondike headquarters for judging. Be on time. Judging will start promptly.

9:00 AM

Announcements

Start of Klondike Tundra Trail Event.

12:00 Noon Sharp!

End of Klondike's Tundra Trail Event.

Noon - 1:00 PM

Lunch is in your campsite.

1:15 PM

Sledge Races at the East end of the parking lot. (Not Mandatory and does not factor towards overall klondike derby award)

After Races-

Awards and patches.

GENERAL INFORMATION

1. Parking of vehicles must be done so that two vehicles are bumper to bumper (nose to tail) in the parking lot. Please make every effort to conserve parking space for others coming in on Saturday to use the facility.

This is the reason for the 26-patrol participation limit with no more than 8 boys per patrol.

2. All campsites will be inspected Saturday morning, after 9 AM. See the campsite inspection criteria below.
NOTE! If your campsite cannot be identified, there is no sense in judging it because no points can be awarded to an unknown patrol. Make sure that your Patrols campsite is identified.

3. Each patrol should bring your first aid kit but leave it in camp on your patrol box for inspection. The events will be close enough to the campsite that if there is an emergency, the first aid kit can be readily accessed.

4. All fire remains from the cooking event (Sourdough Heaven) must be removed after completing this event. Remember, it's a Leave No Trace event!

5. There are two permanent outhouses in the parking lot. We also provide three additional ones (at Klondike expense) in the middle of the parking lot. Please keep them clean.

6. The judges have discretionary nuggets to award for the patrol's scouting spirit, leadership of the patrol leader and general behavior. These nuggets have in the past differentiated the first-place winner from the second and third place winners. They are important!

7. The campsite inspection team will make an effort to inspect every tent or snow shelter to ensure that EVERYBODY has slept on an insulated pad. No Scout should go home with an unpleasant experience from the Klondike by being cold in his sleeping bag.

Sleeping directly on the snow without any insulation under your sleeping bag is not an option.

8. Inspection criteria are based on good camping practices including shelter construction, camp neatness, gateway, food storage techniques, water storage techniques and general overall neatness. A detailed list of criteria is listed below.

9. The fees paid for the Klondike to for miscellaneous expenses including outhouse rental, patches for all boys, ribbons for those placing in the events, insurance, cost of handouts, overhead and hats for the first place overall. Adults are not charged a fee. If adults desire patches, they will be available for \$2 each. The fee for each scout is \$10 each.

10. It is important that you register using the assigned Klondike names. Forms are made up well in advance and patrol names will not be changed.

11. Please do not run the Tundra Trail with your same name from last year unless you managed to get the same name this year. The judges cannot be expected to sort out any confusion caused by two teams running with the same name.

12. For the sledge races, **only those recognizable sledges with their Klondike names** will be scored. Points will be awarded for compliance during sledge inspection at 8:45 AM. Don't miss out on some points which may be helpful for you to win.

WHAT IS The KLONDIKE DERBY?

Briefly, it is this...many years ago, man raced by means of dog and sleds across the frozen wastes of Alaska in search of gold! Scouting has capitalized on this theme and has developed the KLONDIKE DERBY as an activity for Scouts BSA. The patrol names are Klondike names except for two Star War names used by

request. They are Ewoks and Wampas. A Wampa was the big buffalo-like animal that Luke Skywalker rode in a snowstorm on one of the planets. So, it's kind of Klondike related.

These activities are based on useful skills involved in winter camping.

There is a requirement to tie knots. Mr. Graf noticed that despite Scouts learning knots and becoming Eagle Scouts, they fail to be able to tie a square knot or a bowline in early adulthood. Soooooo, have another practice session before you become an adult and become knotless!

To run the Tundra trail, sledges (cargo carrying sleds) and strong boxes must be built. See plans for these below in this handout. The plans are suggested design only. You can vary from the design but stay close to the overall size in the suggested design.

Please note the identification nameplate on the side of the sledge in the plans. Also, since the patrols will be carrying 8 1/2 x 11-inch score cards, a slot to store the scorecard on the sledge is also strongly advised. Points for both the name plates and the score slot will be awarded.

In prior Klondikes the total points for 2nd, 3rd and 4th place were 1905, 1904 and 1902. If the patrol with 1904 total points had gotten the full points for the sledge design, they would have been second overall rather than 4th. Therefore, every point counts.

There are many ribbons awarded. This gives everybody a chance to end up with something. Patrols need to practice doing the events so that they do well in the Klondike. Some events require some practice before coming to the Klondike. Those patrols that practice will look sharp, score a higher number of points than others who do not practice and will have more fun.

The winning patrols usually come to "win". Those that come to "fail" usually succeed in their quest.

Patrols will all start at the same time but can take the events in any order. Please report to Klondike headquarters after completing the Tundra Trail and turn in your scorecard and nuggets.

Extra points will be given for the first, second and third patrols reporting to headquarters.

The Tundra Trail **shuts down at Noon**. If you are participating in an event, you will be allowed to finish it. If you have not started the event by 12:00 Noon you are done.

Nuggets

Each patrol needs a nugget pouch to hold the nuggets. Each nugget collected will be worth an extra 5 points. In 2002, the winning patrol won on nugget count. If the nuggets were not counted, they would not have won first place.

Nuggets are awarded for patrol leadership, patrol spirit and general cooperation of the patrol members with the patrol leader.

Additional nuggets may be awarded at the headquarters when the Patrol Leader turns in the patrol's scorecard and their nuggets. Nugget award is based on patrol spirit.

Note! The first-place winner wins due to patrol spirit as well as doing well on all events.

KLONDIKE DERBY PERSONNEL EQUIPMENT CHECKLIST

1. Warm pants which are also water resistant. **Blue jeans are forbidden!**
2. Warm shirt (wool or appropriate materials preferred)
3. Sweater or windbreaker for layers
4. Coat with hood works best
5. Water repellent boots (moon boots, snow machine boots or snow pacs. Note, an extra set of Snow Pac felt liners ensure warm feet Saturday morning. If the boots are leather, then coat them with silicone to make them water repellent).
6. Knit hat (must be able to cover ears).
7. Socks, wool or polypropylene (1 extra pair for Saturday morning)
8. Gloves or mittens. Mittens are best at keeping hands warm, but an inner light weight glove is handy when working so that a grip can be had on tools, cooking ware etc.
9. Thermal underwear. Loose fitting are best. No cotton. It soaks up moisture and makes you cold.
10. Flashlight with alkaline batteries.
11. Matches & waterproof container.
13. Water bottle for drinking on the Tundra trail.
14. **SCOUT NECKERCHIEF**
15. Thermal insulation for under sleeping bags. Note! All sleeping bags will be checked to see that adequate insulation is underneath for warmth.
16. Adequate sleeping bag
17. Pocketknife.
18. Tarp for under sleeping pad or emergency shelter.
19. Mask for face covering.

KLONDIKE DERBY PATROL EQUIPMENT

1. *Snow shovel
2. *100 feet of rope for Tundra Trail
3. *Patrol Flag with assigned Klondike patrol name
4. *Two sets of snowshoes or skis
5. *Several green logs for Tundra Trail's Sourdough Heaven Cooking Event
6. *Dry firewood for the Sourdough heaven event. Note! No finished lumber pieces. Use natural branches from trees, prepared tinder from local type materials. This would be wood that could be locally gathered although you may bring it from home.
7. *Frying pan to cook the pancake in for Sourdough Heaven event. Note! Cast iron fry pans take a long time to cook a pancake.
8. *Nugget bag
9. *Sledge per sketch in handout or something with similar dimensions
10. *Strong Box for holding gear (see sketch in this handout)
11. *Pancake mix
12. *Spatula
13. *Compass
14. *Claim stakes with your patrol name on it for event #10. A 1 x 2 x 18 inches will do fine.
15. *Tarp and pad for emergency shelter.

*** These items should fit onto your patrol sled for competing in events on the Tundra Trail.**

TROOP/CAMPSITE EQUIPMENT

1. Material for a gateway.
2. First Aid kit.
3. Troop Flag
4. Tents (or prepared snow shelters)
5. Cooking gear
6. Food
7. Appropriate means to safely store food. A cooler chest works fine, bears are not an issue.
8. Shelter for cooking area.

TUNDRA TRAIL

The Tundra Trail consists of ten stations that will require each patrol to perform basic Scout skills. They will be rated on their ability to work effectively as a patrol with a recognized patrol leader. Scout spirit is very important in each event. Read the suggested patrol equipment list carefully and prepare yourselves for the Tundra Trail Event. The first patrol reporting in will be awarded 15 extra points, the second patrol 10 points and the third patrol 5 points.

STATION 1 TINHORN DOCTOR

Sam McGee has cut his leg (severe bleeding) and is showing signs of hypothermia. Treat him appropriately and transport him to Station 1A.

STATION 2 IGLOOLIK

Each patrol member will be asked to tie both a bowline and a square knot. It will be quicker if each Scout has a length of rope.

STATION 3 DESPERATION FLATS

Build an emergency shelter for one scout anywhere within 100 feet of this station. You can only use tools listed under the patrol equipment list.

STATION 4 LUCKY STRIKE GOLD MINE

Your crew will need teamwork and leadership to solve a problem in a timely manner.

STATION 5 KISKA WOODS

Sam McGee would like to know the height of a certain tree is (above the ground, not the snow).

STATION 6 DEAD HORSE CREEK CROSSING

You have to cross Dead Horse Creek. It is springtime and the ice has broken. Other gold miners have strung a 1/2-inch diameter rope and pulley across. It's about 30 feet across. You must get your sledge and two patrol members across without falling in. This event counts for 200 points maximum. All others are 100 points maximum. Be prepared. It helps to practice this one.

STATION 7 LAKE LEBARGE

Lake Lebarge has thin ice. Plan to cross it as safely as possible with all patrol members and sledge. Lake Lebarge is 100 feet across.

STATION 8 BLIZZARD BAY

A sudden spring blizzard catches you in the open country. Only your patrol leader can see the way. He will guide you through the storm. Have faith! All patrol members must participate. Make sure you have the proper gear for this event.

STATION 9 SOURDOUGH HEAVEN

Race to Sourdough heaven where you will cook and eat a pancake at least 3 inches in diameter. You must cook the pancake; flip it over while a judge is watching. You will be judged on how fast you complete this task. Firewood for this event must be natural material from the area. No paper, finished wood, or paraffin dipped wood.

STATION 10 FRENCH JOE'S KLONDIKE CLAIM

Here you will be given directions to your partner's claim. You will have to locate it and stake your claim by putting your claim stake into the location that you determine. Leave your claim stake in the snow.

After you have finished all events, or it is 12:00 Noon report back to Klondike Headquarters and turn in your score sheet and your nuggets by 12:30PM so that we can tally the scores and determine the winners.

SLEDGE RACES will be in the afternoon at 1:15 PM

Enter your 3-man team in the sledge races.

The races will be divided into ages 11-13, 14+, also adults.

You can substitute a younger Scout in a race, but you cannot substitute an older one.

All 3 Scouts and sledge must cross the finish line.

One member must ride on the sledge.

The other two can either push or pull. Both can do the same.

You figure out the best way.

If you are going to enter the sledge races you **MUST** have your Klondike selected name on each side of the sledge. The judges do not have crystal balls to figure out who you are. Year after year, sledges are at Klondike without any identification. Since the staff puts in a lot of effort to make Klondike a success, an unnamed Klondike sledge means you didn't really plan on winning anything and, that's likely to be the case. Scoutmasters, please do this for your Boys.

AWARD PRESENTATIONS will follow the sledge races.

KLONDIKE RIBBON AWARDS

First, second and third place ribbons for:

1. Most Points overall Klondike Derby
2. Tundra Trail
3. Best Campsite
4. Sledge Races
11 - 13, 14+ years old and adults.
5. Gateway
6. Sledge Design and Construction
7. Patrol Flag
8. Special ribbon for special recognition.

FIRST PLACE OVERALL PATROL

You will receive hats that have "Klondike Derby First Place" Your picture will be taken and sent to the Scout Office to be put in the Web Page.

HOW AWARDS CAN BE EARNED

PATROL CAMP INSPECTION CRITERIA

MAXIMUM POINTS:

Adults note: This is a competition for the boys who are separated into patrols of no more than 8 boys. The campsite should be set up by the boys to show their ability. Give them a chance to show what they can do.

- 50 No trace camping
- 100 Appropriate quality of snow shelters (tents can be used but no points given)
- 50 First Aid Kit
- 25 Bulletin Boards
- 25 Duty Roster posted.
- 25 Menu posted.
- 100 Cooking area clean and neat (10-point deduction for each item left out.)
- 25 Garbage Container
- 100 Sleeping area clean and neat
- 100 Gateway for troop and for patrol
- 50 Appropriate storage of food
- 50 Appropriate storage of water so that it does not freeze
- 100 Adequate snow shelter for cooking area (to keep snow and wind away from the cooking area)
- 200 Adequate insulation under EVERY sleeping bag.
- 50 Patrol presents itself for pack inspection.

1050 Points Maximum

Judges need to be able to find the camp areas which means a sign to direct them will go a long way. If judges cannot find youth camp areas or youth are camping with adults, judges have been instructed to not award a grade for said patrol. These points go a long way in deciding the winner of klondike overall.

TUNDRA TRAIL:

100 points maximum for each event except the Dead Horse Creek Crossing Event which is a 200-point event (1100 max. total). This event starts when the sledge and patrol flag judging is completed at 9 AM.

NUGGETS

Each nugget is worth 5 points. This is added to the tundra trail points.

FINISHING

The first patrol reporting in will be awarded 15 extra points, the second patrol 10 points and the third patrol 5 points. This is added to the tundra trail points.

SLEDGE RACES

The sledge races cannot be counted for the overall awards due to time limitations.

GATEWAYS

The Troop gateways are judged in the morning during the time the patrols are running the Tundra Trail. A predominantly snow gateway is suggested.

SLEDGE DESIGN AND PATROL FLAG JUDGING

The sledges and patrol flags are judged at 8:30 AM

NOTE

Below is an example from 2016 that will show you how important the various opportunities to improve your score are.

Note how close some patrols were and where they fell in picking up some easy give away points.

KLONDIKE DERBY OVERALL PATROL SCORES FOR 2016

| | <i>Sledge Patrol Name</i> | <i>Troop</i> | <i>Tundra Trail</i> | <i>Camp Inspection</i> | <i>First, 2nd or 3rd in</i> | <i>Patrol Spirit ,Nuggets</i> | <i>Sledge Extra Pts</i> | <i>Other Extra Pts. Pack Inspection</i> | <i>TOTAL POINTS</i> |
|----|---------------------------|--------------|---------------------|------------------------|-----------------------------|-------------------------------|-------------------------|---|---------------------|
| 1 | BADGERS | | | | | | | | |
| 2 | BOBCATS | | | | | | | | |
| 3 | CARIBOU | 168 | 420 | 560 | | 60 | 75 | 49 | 1164 |
| 4 | COYOTES | 249 | 1030 | 1050 | 15 | 150 | 90 | 94 | 2429 |
| 5 | EWOKS | | | | | | | | |
| 6 | GRAY FOXES | 275 | | | | | | | |
| 7 | GRIZZLY BEAR | 136 | 543 | 40 | | 55 | 82 | 43 | 763 |
| 8 | HARPOONS | | | | | | | | |
| 9 | KODIAK | 159 | 855 | 820 | | 140 | 85 | 73 | 1973 |
| 10 | KING CRAB | 202 | 932 | 873 | 5 | 95 | 85 | 79 | 2069 |
| 11 | KILLER WHALES | | | | | | | | |
| 12 | MALAMUTE | 168 | 930 | 737 | | 130 | 70 | 97 | 1964 |
| 13 | MOOSE | | | | | | | | |
| 14 | MUSK OXEN | 136 | 533 | 37 | | 55 | 50 | 17 | 692 |
| 15 | OSPREYS | 249 | 841 | 1049 | | 110 | 86 | 70 | 2156 |
| 16 | OCRAS | | | | | | | | |
| 17 | POLAR BEARS | 228 | 846 | 524 | | 85 | 74 | 73 | 1602 |
| 18 | REINDEER | | | | | | | | |
| 19 | SEALS | | | | | | | | |
| 20 | SEA HAWKS | | | | | | | | |
| 21 | SEA OTTERS | | | | | | | | |
| 22 | SNOW CRABS | 159 | 1033 | 925 | 10 | 155 | 95 | 79 | 2297 |
| 23 | SNOW DOGS | 159 | 1005 | 917 | | 110 | 80 | 52 | 2164 |
| 24 | WAMPAS | | | | | | | | |
| 25 | WOLVERINES | 602 | 755 | 483 | | 100 | 75 | 61 | 1474 |
| 26 | YUCONS | | | | | | | | |

KLONDIKE
STRONG BOX
Suggested Design

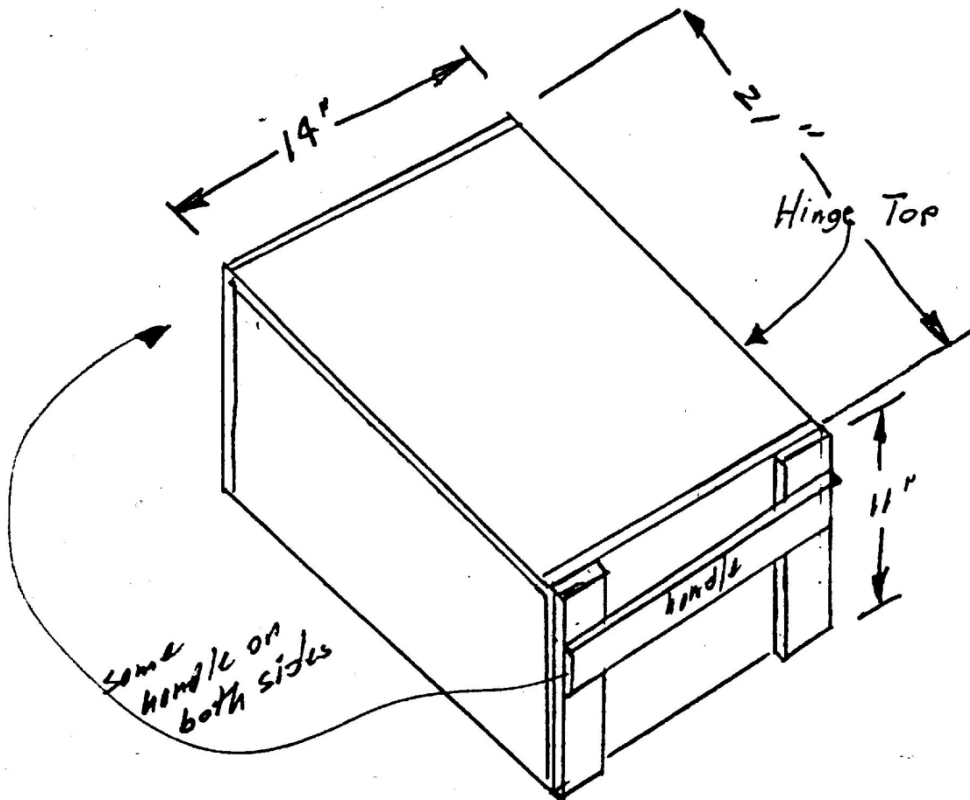

3/4" plywood top, bottom and sides

SLEDGE
CONSTRUCTION
DETAILS

Note:
Use screws to
fasten.

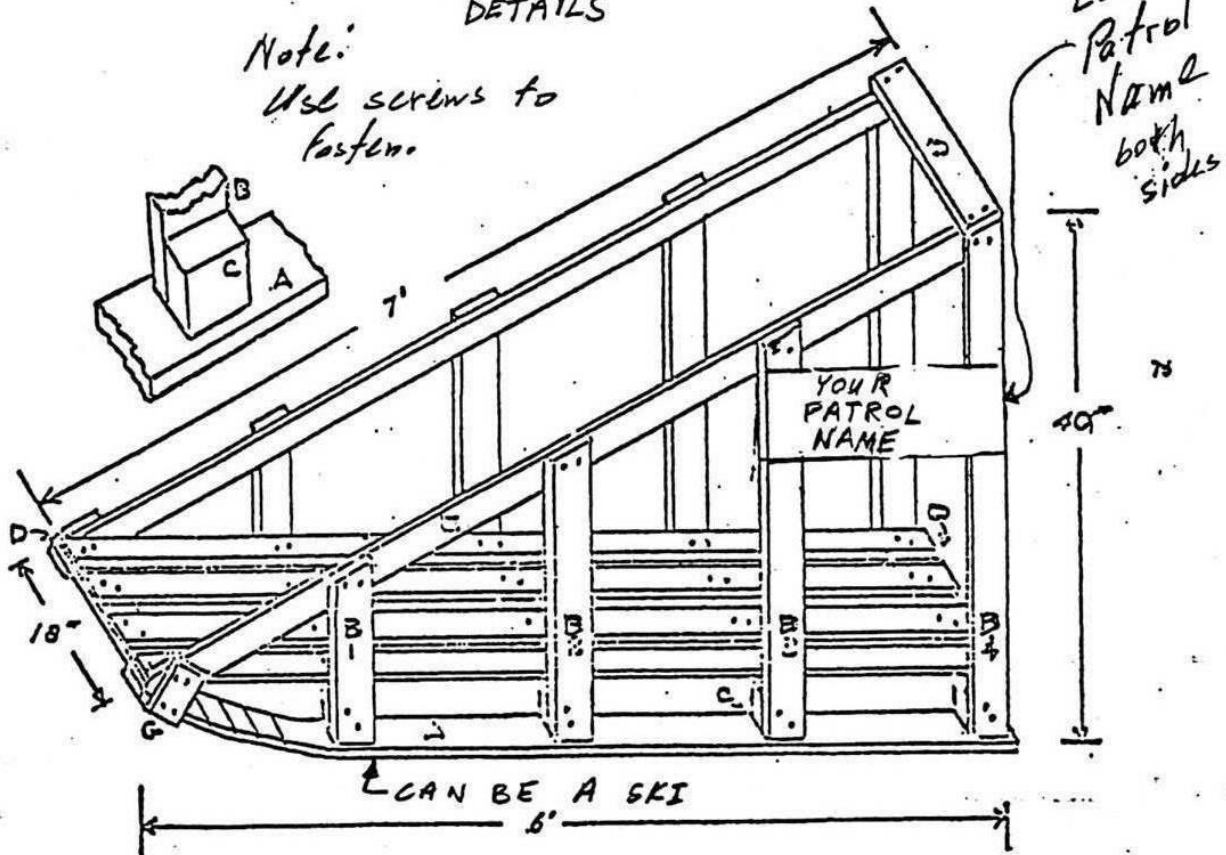

| BILL OF MATERIAL | | | |
|------------------|-----|------------|-------------------|
| Part | Key | No. Pieces | Dimensions |
| Runners | A | 2 | 1" x 4" x 6" |
| Uprights | B1 | 2 | 1" x 4" x 3 1/2" |
| | B2 | 2 | 1" x 4" x 2 7/8" |
| | B3 | 2 | 1" x 4" x 1 9/16" |
| | B4 | 2 | 1" x 4" x 10" |
| Upright supports | C | 8 | 2" x 4" x 4" |
| Cross supports | D | 6 | 1" x 4" x 1 1/2" |
| Floor strips | E | 4 | 1" x 4" x 6" |
| Hand rails | F | 2 | 1" x 2" x 7" |
| Front supports | G | 2 | 1" x 4" x 6" |

or set of ski.
You can vary the design but keep the overall dimensions the same.