

James River District Klondike Derby

Heart of Virginia Scout Reservation



FEBRUARY 7-9, 2025

The Scout Oath

On my honor I will do my best,
To do my duty to God and my Country,
And to obey the Scout Law;
To help other people at all times;
To keep myself physically strong, mentally awake and
morally straight.

The Scout Law

A Scout is: Trustworthy
Loyal, Helpful
Friendly, Courteous
Kind, Obedient
Cheerful, Thrifty
Brave, Clean
and
Reverent

T. Brady Saunders Graces Breakfast

Gracious giver of all good,
Thee we thank for rest and food.
Grant that all we do or say,
In Thy service be this day.

Lunch

Father for this noonday meal,
We would speak the praise we feel
Health and strength we have from Thee
Help us Lord to faithful be.

Dinner

Tireless Guardian on our way,
Thou has kept us well this day.
While we thank Thee, we request
Care continued, pardon rest.

Scout Vespers

Softly falls the light of day
as our campfire fades away.
Silently each Scout should ask,
"Have I done my daily task?
Have I kept my honor bright?
Can I guiltless sleep tonight?
Have I done and have I dared
everything to Be Prepared?"

Mission Statement- The mission of the Boy Scouts of America is to prepare young people to make ethical choices over their lifetimes by instilling in them the values of the Scout Oath and Law.

Vision Statement - The Boy Scouts of America is the nation's foremost youth program of character development and values-based leadership training. In the future Scouting will continue to

- Offer young people responsible fun and adventure;
- Instill in young people lifetime values and develop in them ethical character as expressed in the Scout Oath and Law;
- Train young people in citizenship, service, and leadership;
- Serve America's communities and families with its quality, values-based program.

General Information

What is the James River District Klondike Derby?

The Klondike Derby is a Scouts BSA Winter skills and camping event. (Camping is optional for Cub Scouts.) The weekend involves overnight camping and multiple Camporee-type activities and competitions. When the Scouts arrive at the various activity stations, they are timed and tested on their Scouting knowledge, teamwork, and problem solving skills. Based on the skills, knowledge, and Scout spirit they demonstrate at each station, the Scouts will receive “gold nuggets” as a means to keep score and to use to purchase items at the evening equipment auction.

When is the James River District Klondike Derby?

The Klondike Derby will be held February 7-9, 2025, when there is a good chance of having cold weather and a layer of snow on the ground. The Scouts/Venturers will have to make do in the rain, mud, slush or even just on frozen ground. The Scouts never know exactly what they’ll be working with until the weekend of the event, so they have to be prepared for anything!

Who can attend the James River District Klondike Derby?

This Klondike Derby is open to members of all BSA programs. While the Klondike Derby is a quintessential Scouts BSA event, the James River District event is also open to Venturing Crews and Cub Scouts. Webelos Scouts are invited to attend either as part of a Scouts BSA Patrol or as their own Webelos Patrol. And younger Cub Scouts can attend and participate in a Chuck Wagon Derby version of the Klondike, using wagons and Cub Scout-level challenges.

Where is the James River District Klondike Derby?

The Klondike Derby is being held at the Heart of Virginia Scout Reservation in Goochland County, Virginia. Directions to the Scout Reservation are included in this guide.

What are the James River District Klondike Derby Activities?

The Klondike Derby consists of a series of challenge stations where Patrols are timed and tested on their Scouting knowledge, teamwork, and problem solving skills. Each Patrol travels between stations working as a “dogsled” team, using Scout power to pull the sled instead of dogs. Each Patrol will be assigned a unique set of bearings that they will follow to navigate from station to station using map and compass. Scouts pull their sleds loaded with required sled team equipment through woods and fields, up and down hills, stopping at the various stations where they earn “gold nuggets” based on their performance. Some of the skills on which they may be tested will include:

- Sled and equipment inspection
- Map and compass navigation
- Fire building
- Slingshot accuracy
- Knots/lashings
- Cooking
- First aid
- Pioneering skills
- Campsites
- Emergency signaling
- Communication
- Woods tools
- Physical fitness
- Mental agility
- Sled race
- Patrol skits

The Sled

With the exception of Cub Scouts (who can choose to use a wagon), every competing team needs an official Klondike sled. The sleds are fashioned to look somewhat like Alaskan dog sleds. Some materials that are used include plywood, pine boards, old fiberglass and wood skis for the runners, wooden dowels, old broom sticks and handles, wood screws, nuts and bolts, rope, etc. Sometimes PVC pipes can be used to form the body of the sled. It's not recommended to use nails in the construction of the sled because they come loose under the stress, strain, and banging the sleds take. Prior to the Klondike Derby weekend, teams that will be participating will be given a required equipment list and a set of plans for building a sled.

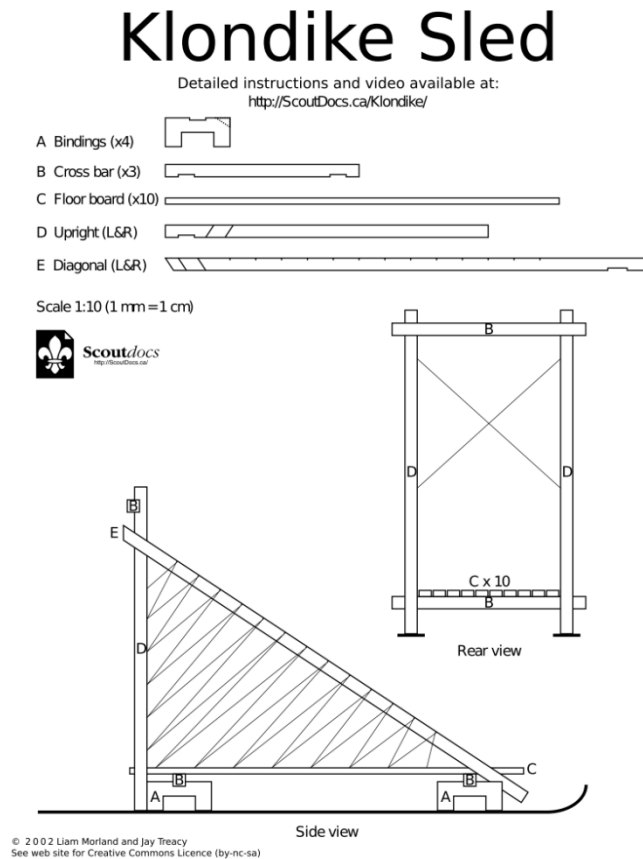

Harness Design

A comfortable harness can be easily made by making a loop from 2m (6') of 2.5cm (1") nylon webbing. To this is tied a rope which leads back to the bindings on one side or the other of the sled. Ensure that an equal number of Scouts are pulling on either side. If you like, tie a short piece of bicycle inner tube from the webbing loop to partway down the rope. This allows some give in the harness which will keep the tension more constant. Ensure that if the harness is pulled hard, such as when climbing a steep hill, the rope will become tight and do the pulling itself. Otherwise, something may give way unexpectedly and the sled may fly forward with all the energy stored in the over-stretched inner tube.

In addition to the pull harnesses, there must be a brake rope. This is a short rope tied between the two rear bindings. This is used by the musher to stop the sled. Note that the musher must not get into the rope as a sudden pull could pull the musher face-first into the push bar.

LOCATION AND DIRECTIONS

Heart of Virginia Council Reservation
Boy Scouts of America
1699 Maidens Rd.
Maidens, Virginia 23102
Phone: 804-204-2625

- **From Richmond, Virginia – go west on Interstate 64, US Route 250 (Broad Street), or State Route 6 (Patterson Avenue) for approximately 27 miles.**
- **Route 6 West – From Richmond, take State Route 6 (Patterson Avenue) west past Crozier and the State Farm, to the first traffic light (US Route 522 and Route 634). Turn right (north) on Route 624 to camp.**
- **From the South via US Route 522 – US Route 5ss connects with US Route 60 west of Richmond. Proceed north on US Route 522. Cross the James River at Maidens. Continue straight through traffic light to Camp on Route 634.**
- **Via Interstate 64 – Take Interstate 64 to the Oilville exit. Turn south on Route 617 to US Route 250. Turn right (west) on US Route 250. Turn left (southwest) on Route 632, then turn left (southeast) on Route 634 to Camp. Note the brown highway signs that lead into camp starting at US Route 250.**
- **Via US Route 250 – From Richmond, Take US Route 250 (Broad Street Road) west past Oilville to Route 632. Turn left (southwest) on Route 632, then turn left (southeast) on Route 634 to Camp. Note the brown highway signs that lead to camp starting at Route 250 and Route 632 intersection.**

Heart of Virginia Scout Reservation

Cub Adventure Camp • Camp S. Douglas Fleet • Camp T. Brady Saunders

Owned and operated by:
Heart of Virginia Council #602
Boy Scouts of America
Richmond, Virginia
at Maidens, Virginia

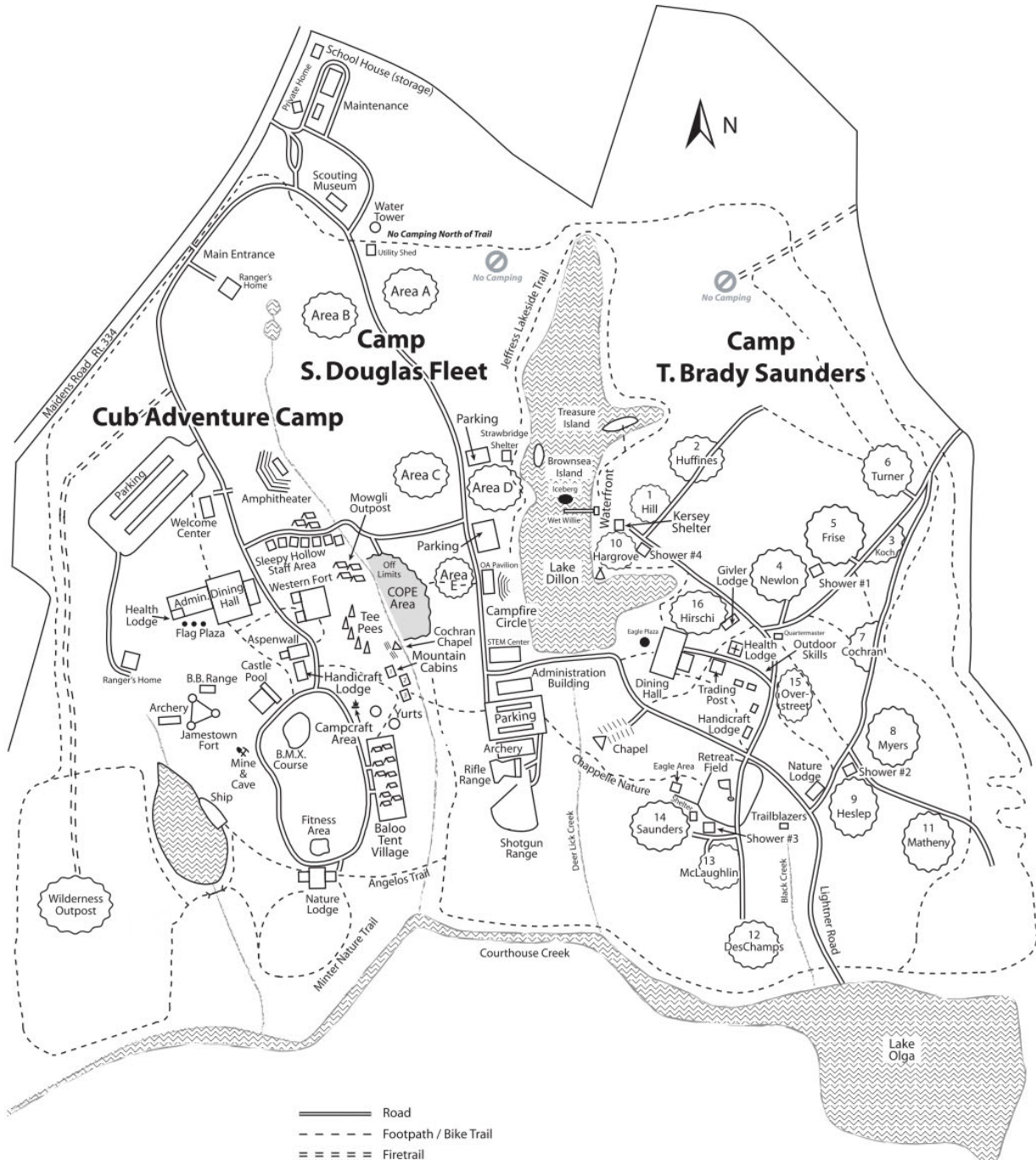

CHECK-IN AND CHECK-OUT PROCEDURES

Check-In Procedures

Plan for your Unit to arrive at Fleet / TBS between 5:00 PM and 8:30 PM on Friday. Cub Scouts attending for the day should arrive between 7:30 AM and 8:30 AM on Saturday.

Signs will designate where the check-in will be and where to park. One adult leader and the Senior Patrol Leader should go to the designated location for check-in.

At Check-In, be prepared to:

- Present a final Unit roster of all present (leaders and scouts).
- Turn in completed medical form for each person part A and B (youth and adult) – please submit a copy & not your original medical forms.

Fully loaded vehicles (loaded with gear, not Scouts) will be permitted to go to the campsite or building and then, once unloaded, immediately return to the nearest parking lot, a trailer may be left at the site. No vehicles can be left on the roadside in camp; all vehicles must be moved to the parking lot by 9pm.

NO SCOUTS OR SCOUTERS MAY RIDE IN THE BACK OF A TRUCK!

Check Out Procedures

- After breakfast on Sunday, one vehicle per Unit will be allowed to park on the roadside near the Unit's campsite to remove gear starting at 9am.
- PLEASE CLEAN CAMPSITES BEFORE CHECKOUT.
- Go to the Administration building to receive your medical forms.

Vehicles In Camp

All vehicles must be parked in established parking areas on either side of Fleet Campsite D or at the TBS administration building.

No vehicles will be allowed across the dam into Camp TBS without a program vehicle pass.

BUDDY SYSTEM

The buddy system is to be used at all times while at camp. When campers are not with their unit, they must have a buddy who is roughly their age. All buddies are responsible for monitoring each other's safety and shall report injuries to Camp Leadership. In case of inclement weather, buddies should stay together and report to the appropriate safety location.

EMERGENCY PROCEDURES

*BSA Health Forms Parts A and B **must** be turned in for all participants at Check-In.*

MEDICAL EMERGENCIES

Report all medical emergencies at the Administration Building.

IN THE EVENT OF A FOREST FIRE, BUILDING FIRE, EXPLOSION OR THE NEED FOR THE CAMP LEADER TO COMMUNICATE TO ALL PARTICIPANTS CONCERNING AN EMERGENCY, the following procedures will go into action:

- I. Fire/Emergency reported to the Administration Building at once.
 - A. Contact the Camp Leadership at once.
 - B. Sound the alarm (three blasts).
 - C. Contact Unit Adult Leadership at once.
- II. Alarm is sounded (three blasts)
 - A. Adult Leaders report to the retreat field area and await orders from Camp Leadership.
 - B. All youth and adults report to the STEM/OA field, assemble in retreat formation. If fire is blocking the road/trail, reroute to an unaffected road/trail.
- III. Patrol Leader / Senior Patrol Leader
 - A. Conduct Roll Call and report count to Scoutmaster.
 - B. Prepare to evacuate Scouts and families.
 - C. Wait at retreat field for instructions from Scoutmaster or Camp Leadership.

LIGHTNING POLICY

- A. At the first sign of thunderstorm or bad weather:
 - a. All campers take shelter in the nearest building or under a permanent shelter, if possible. If not, go to low elevations, ideally away from the direction of the approaching storm. A dense forest located in a depression offers the greatest protection. Stay away from open fields and spaces, and high places.
 - b. All activities near water will stop and participants will move away from the water. Listen for any additional instructions from camp leadership.
- B. If it is storming or threatening to storm during meal time, campers should move to the nearest building or permanent structure until the threat of lightning has ended.
- C. At night time or if in campsite or program areas when storm threatens or arrives:
 - a. Campers should go, if safely possible, to the nearest building or permanent structure (but not showers or latrines), or personal vehicles, until the storm is over.
 - b. Otherwise, campers should move to lower elevation. A dense forest located in a depression offers the greatest protection.
 - c. Campers should stay clear of bodies of water, metal fences and poles, and anything else that might conduct electricity. In a tent, stay away from metal tent poles.
 - d. Campers should spread out in a lightning storm so that people are at least 30 feet from one another; they should crouch low with only the soles of their shoes touching the ground and use a sleeping pad for insulation by folding it and crouching upon it.
- D. Activities may resume 30 minutes after the last thunder is heard.

WILDLIFE CONCERNS

Wildlife always present with potential threat:

Copperhead Snakes
Yellow Jackets

Black Widow Spiders
Ticks

Chiggers
Skunks

Snakes:

Snakes can be found in wood piles and around buildings. When approached they will either move away or lay motionless, relying on camouflage to protect them. Often, they are seen lying on warm roads in early evening. The Copperhead is aptly named. It has a red copper color with a broad triangular head. The body is pinkish to grayish brown or reddish-brown cross-bands that narrow on the back and widest on the sides. Copperheads prefer forested hillsides and wetlands for habitat.

Precaution: Keep watch where you step, do not blindly step over large objects such as fallen trees, and carry a flashlight when walking at night.

Yellow Jackets:

All wasps will defend their nest, but Yellow Jackets are the most aggressive. They can be distinguished from bees by their thin "waists". Bees are thick-waisted. Yellow Jackets fold their wings lengthwise when at rest. Like all wasps, Yellow Jackets prey on a variety of insects and other arthropods. Yellow Jackets will also forage on food that people eat, especially sweets and meats. They are considered beneficial insects, eating other insects. The Yellow Jacket colony will remain active for only one summer, after which the queens will fly away to start more colonies. The remaining ones die at the end of the summer and the nest is not reused. They usually nest in the ground. They will nest in old railroad ties, wall voids, dead trees, and a few other above ground locations. In camp, they may be seen flying around bushes feeding and in dry weather at locations where moisture oozes from trees or accumulates on the ground. The colony is usually buried in the ground with the only visible sign of a hole about the size of a quarter or larger. If the colony is disturbed they can become very aggressive and sting. The sting is temporary but very painful and for Scouts and Scouters with allergies a lethal threat. Walking on or stepping on them in the woods or open field disturbs most nests.

What to do if a nest is located:

- Get anyone who has been stung to the Administration Building at once. Camp Leadership will review the Scout or Scouter and provide proper treatment.
- Mark the area and keep others away even if you have not located the opening in the nest. Please get the Camp Leadership involved. They will visit the site during the daylight hours and will come back after dark to treat the nest if necessary.

Precaution: Watch your step.

Black Widow Spiders:

These spiders inhabit damp, dark places. Typically they will be found in leaf / wood debris and in building corners. If they are trapped against someone's skin they will bite. The bite can be very painful and often results in other side effects. If you should suspect that you have been bitten, report it to Camp Leadership immediately.

Precaution: Examine your tent and bedding nightly before entering.

Ticks and chiggers:

Ticks and chiggers are generally present from March through October. They are most commonly found in grassy areas or in wooded areas with leaf / wood debris. They are best avoided by wearing light colored clothing and insect repellent. Inspect yourself for parasites at least once per day. When a tick is found attached to a person, report it to Camp Leadership for removal and treatment. Chiggers are invisible mites that leave red welts which itch for days.

Precaution: Insect repellent, inspections, avoidance of grassy areas and wooded edges.

Wildlife that could be dangerous, and may not run from your presence:

- Raccoon
- Fox (both gray and red)
- Skunk
- Coyote

Raccoons, foxes, and skunks are nocturnal animals that are attracted to food and garbage. To minimize exposure and problems with these species be sure to keep a clean camp and do not bring food into tents. Skunks can be a bad nuisance, particularly when they have established a routine pattern of campsite inspections. Do not tease, goad, or otherwise offend a skunk; you may be sprayed! Black bears are generally crepuscular (most often active at dawn and dusk). As with other animals, bears are attracted by food and garbage.

Precaution: Maintain clean campsites and contact Camp Leadership if a pattern of animal behavior continues or becomes dangerous.

Wildlife that could be dangerous, and should run from your presence:

- Groundhog
- Feral cats and dogs

It can be assumed that these mammals that are indigenous to the area and should be trying to avoid human contact. If this is not the case these animals should be avoided at all costs - these animals can be assumed to be sick and dangerous. Keep all campers away from these animals and contact Camp Leadership at once, giving location and conditions.

Precaution: Be aware of suspicious animals and have all campers leave the area and direct others away from the area.

GENERAL CAMP PROCEDURES

MEALS

Patrols will prepare their own meals at their campsite.

Food may not be stored in tents.

Gold nuggets will be awarded for Patrol meal plan and Duty roster.

CAMPSITES

When you check in, you will be assigned to a Patrol Campsite.

Campers are responsible for the following:

- Trash removal from camp.

- Campsite cleanup to be equal or better than you found it.

- Leave No Trace: Wood is returned to the woods. Do not bring your own wood.

- Camp safety and adherence to BSA policy found in "Guide to Safe Scouting."

- Latrine maintenance.

- Returning campsites to natural conditions at the end of camp.

Cooking areas must be at least 100 feet from sleeping areas.

Food storage (to include smellables) must be at least 100 feet from sleeping areas.

Quiet time is from 10PM to 6 AM.

TENTING

Tent trenching is not allowed.

Extension cords that are properly grounded and meant for outdoor use are allowed overnight for medical purposes.

All liquid fuel must be stored outside and is not allowed in tents.

Open flames in tents are prohibited. Please use only flashlights within tents.

CAMPFIRES (upon arrival, you will be notified if there are any restrictions)

ALL CAMPFIRES MUST BE IN FIRE RINGS OR OTHER APPROVED AREAS.

DO NOT BRING FIREWOOD FROM OUTSIDE CAMP, IT CAN SPREAD INSECTS TO OUR FORESTS!

A campfire must be monitored at all times.

A fire bucket must be present at all campfires.

Campfire must be cool to the touch before it is left unattended.

Where charcoal and charcoal lighterfluid is used, the lighter fluid must be stored outdoors.

Do not leave firewood stacked at unoccupied campsites – Stacked wood or wood in the grass can harbor snakes or other pests.

Event Schedule

	<u>Time</u>	<u>Event</u>
FRIDAY	6:00 - 9:30pm	Check-in
	9:30 PM	SPL/SM Meeting
	10:00 PM	Call to Quarters*
	11:00 PM	Lights Out
SATURDAY	7:00 AM	Reveille
	7:15 AM	Breakfast
	8:30 AM	Patrol Equipment Inspection
	8:50 AM	Opening Ceremony
	9:00 AM	Klondike Derby Start
	12:30 – 1:30 PM	Lunch
	4:30 PM	Stations Close
	4:45 PM	Klondike Sled Race
	5:15 PM	Equipment Auction
	5:45 – 7:30 PM	Dinner at Campsite
	7:45 PM	Awards Campfire
	10:00 PM	Call to Quarters*
	11:00 PM	Lights Out
SUNDAY	7:00 AM	Reveille
	7:15 AM	Breakfast
	8:45 AM	Scouts Own Service
	9:00 – 10:00 AM	Check-out and Departure

* Patrol Leaders count heads to make certain all your Scouts are present.

Each Scout Unit will be required to provide a minimum of one volunteer to staff the Klondike Derby Challenge Stations.

Each Patrol is expected to participate in the campfire program by performing a skit, song, or run-on. To earn gold nuggets for participating, the Patrol must submit a skit signup form by Saturday Lunch.

Each Patrol is asked to provide one volunteer to read at the Sunday service.

KLONDIKE DERBY PROGRAM

CHALLENGE STATIONS:

The Klondike course will include challenge stations based on Scout skills such as fire building, first aid, woods tools, knots & lashings, camping, and Scout history. Patrol's will plan and bring their own meals, and the Cooking Challenge will be scored based on the Patrol's menu, budget, duty roster, and cleanup.

THE DERBY:

Scouts will compete as patrols of up to eight Scouts. At the start of the Derby, Scouts will go to their first assigned station and complete the challenge to the best of their ability. Each station will require Scouts to demonstrate Scouting skills, team work, and problem solving, with emphasis on Patrol Scout spirit.

A maximum of 20 "gold nuggets" will be awarded by each of the station managers based on the following criteria:

Successful completion of task = up to 10 nuggets;

Timely completion of task = up to 2 nuggets;

Good Team work = up to 4 nuggets;

Positive Scout spirit = up to 4 nuggets.

Patrol Leaders are responsible for collecting any gold nuggets earned at each station prior to their Patrol leaving for the next station. If the Patrol leaves before collecting the gold nuggets, they forfeit those nuggets and cannot go back to collect them. Lost nuggets cannot be replaced.

EQUIPMENT AUCTION:

Each Patrol must bring one or more items to donate to the Equipment Auction. Items should be Scouting or outdoor related, such as flashlights, knives, backpacks, uniform parts, compasses, tents, etc. Patrol Leaders should turn in these items at the Friday SPL/SM meeting. At the Auction, each Patrol will have an opportunity to use their gold nuggets to bid for the donated items.

KLONDIKE DERBY RULES:

Each Patrol must have a sled equipped with all of the equipment they will need for the Derby. Challenge Stations that require materials not listed as Required Sled Gear will provide those materials.

Basic rules are:

Patrols may have a maximum of eight Scouts.

Patrols must follow the designated course and attempt all of the challenges.

Patrols must show Scout spirit throughout the course and stations.

Sleds must have skis or runners for travel through the course.

All sleds must be pulled by Scouts (no gas, electric, or other mechanical sleds).

CHUCK WAGON DERBY PROGRAM

CHALLENGE STATIONS:

The Chuck Wagon Derby course will include the same challenge stations as the Klondike Derby, but with Cub Scout-level challenges for each of the Scout skills.

THE DERBY:

For the Chuck Wagon Derby a Cub Scout den will be the equivalent of a patrol. Each Cub Scout should be accompanied by a parent/guardian. At the start of the Derby, Cub Scouts will go to their first assigned station and complete the challenge to the best of their ability. Each station will require Cub Scouts to demonstrate Scouting skills, team work, and problem solving, with emphasis on Patrol/Den spirit.

A maximum of 6 “gold nuggets” will be awarded by each of the station managers based on the following criteria:

Successful completion of task = up to 2 nuggets;

Timely completion of task = up to 1 nuggets;

Good Team work = up to 1 nuggets;

Positive Scout spirit = up to 2 nuggets.

Den Leaders are responsible for collecting any gold nuggets earned at each station prior to their Den leaving for the next station. If the Den leaves before collecting the gold nuggets, they forfeit those nuggets and cannot go back to collect them. Lost nuggets cannot be replaced.

EQUIPMENT AUCTION:

Each Den must bring one or more items to donate to the Equipment Auction. Items should be Scouting or outdoor related, such as flashlights, knives, backpacks, uniform parts, compasses, tents, etc. Den Leaders should turn in these items by 8:30 AM on Saturday. At the Auction, each Den will have an opportunity to use their gold nuggets to bid for the donated items.

CHUCK WAGON DERBY RULES:

Each Den must have a wagon (or sled) equipped with all of the equipment they will need for the Derby.

Challenge Stations that require materials not listed as Required Sled Gear will provide those materials.

Basic rules are:

Each Cub Scout must have a parent/guardian with them during the Derby.

Dens must follow the designated course and attempt all of the challenges.

Dens must show Scout spirit throughout the course and stations.

James River District Klondike Derby 2025

Sled Inspection Form

This form must be presented at the Saturday Patrol Sled Inspection and kept on the sled until the end of the Derby.

Unit Number: _____

Sled Inspector: _____

Patrol Name: _____

Patrol Leader: _____

Item	Gold Value	Gold Earned
Inspection Form	1	
Campfire Skit Form	5	
Patrol Meal Plan and Duty Roster	5	
Patrol Flag (Visibly displayed)	5	
Scouts BSA Handbook	1	
Pencil and Paper	1	
Container for Gold Nuggets	1	
Two Tarps	2	
50-foot Rope	1	
Compass	1	
Patrol First Aid Kit	2	
Three 6-foot Poles	3	
Fishing Rod	1	
Ax, with Sheath	2	
Hatchet, with Sheath	2	
Bow Saw, with Sheath	2	
Fire Starter Kit (Kindling, Flint & Steel, Lighter)	3	
One 2-person or 3-person Tent	1	
Drinking Water	5	
Sack Lunches	5	
Trash Bag	1	
Sled is equipped with ropes and can be pulled by Scouts	10	
Gear is safely stowed for travel	5	
Total	60	

James River District Klondike Derby 2025 Patrol Roster

This form must be presented at the Saturday Patrol Sled Inspection and kept on the sled until the end of the Derby.

Unit Number: _____ Patrol Name: _____

Patrol Leader: _____

Patrol Members:

_____	_____
_____	_____
_____	_____

James River District Klondike Derby 2025 Patrol Roster

This form must be presented at the Saturday Patrol Sled Inspection and kept on the sled until the end of the Derby.

Unit Number: _____ Patrol Name: _____

Patrol Leader: _____

Patrol Members:

_____	_____
_____	_____
_____	_____
