

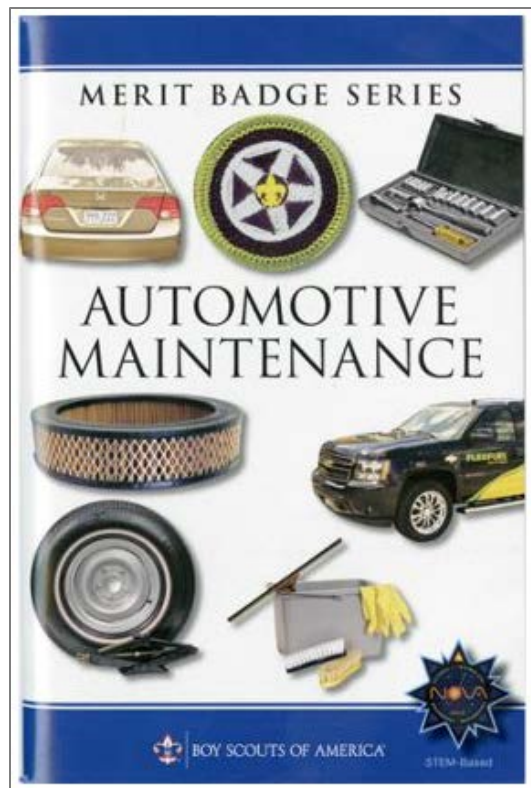

# Automotive Maintenance Merit Badge



*Be Car Care Aware*



Produced by: **Scoutworks**  
[www.scoutworks.weebly.com](http://www.scoutworks.weebly.com)  
May 2016



# What You Need to Complete this Merit Badge

## Required

Click on the link for instructions on how to fill it out

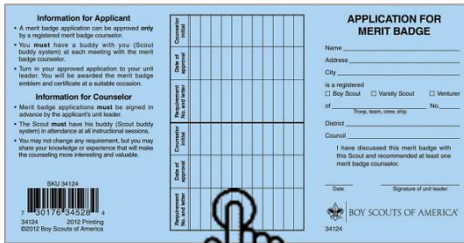

**Information for Applicant**

- A merit badge application can be approved **only** by a registered merit badge counselor.
- You must have a buddy with you (Scout buddy system) at each meeting with the merit badge counselor.
- Turn in your approved application to your unit leader. You will be awarded the merit badge emblem and certificate at a suitable occasion.

**Information for Counselor**

- Merit badge applications must be signed in advance by the applicant's unit leader.
- The Scout must have his buddy (Scout buddy system) in attendance at all instructional sessions.
- You may not change any requirement, but you may share your knowledge or experience that will make the counseling more meaningful and usable.

**APPLICATION FOR MERIT BADGE**

Name \_\_\_\_\_  
 Address \_\_\_\_\_  
 City \_\_\_\_\_  
 Is a registered  Boy Scout  Varsity Scout  Venturer  
 if \_\_\_\_\_ Yes  No   
 Troop team, crew, ship \_\_\_\_\_  
 District \_\_\_\_\_  
 Council \_\_\_\_\_  
 Name discussed this merit badge with this Scout and recommended at least one merit badge counselor \_\_\_\_\_  
 Date \_\_\_\_\_ Signature of unit leader \_\_\_\_\_

BOY SCOUTS OF AMERICA  
34124



Blue Card  
(from your Scoutmaster)



Merit Badge Counselor

## Highly Recommended

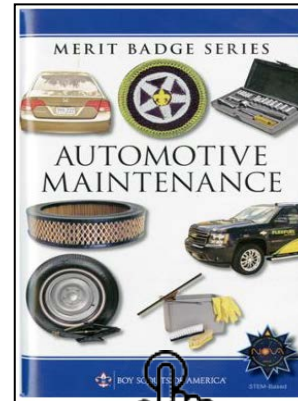

Automotive Maintenance Pamphlet  
(from the troop library or the scout store)

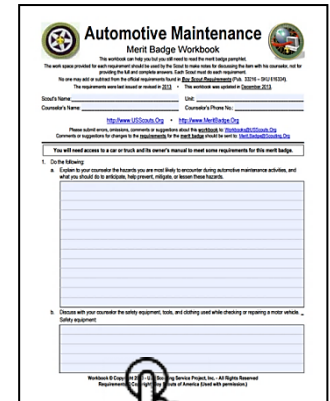

**Automotive Maintenance Merit Badge Workbook**

This workbook can help you do all that is needed to earn the merit badge. The workbook includes all the information you need to know about the merit badge. It also includes a list of all the requirements for the merit badge. You will need to complete this workbook before you can take the merit badge exam.

Scout's Name \_\_\_\_\_ Unit \_\_\_\_\_  
 Counselor's Name \_\_\_\_\_ Counselor's Phone No. \_\_\_\_\_

Please submit your answers, responses or suggestions about this application to [MeritBadges@Scout.org](mailto:MeritBadges@Scout.org)  
 Comments or suggestions for changes to the application for the merit badge should be sent to [MeritBadges@Scout.org](mailto:MeritBadges@Scout.org)

**The merit badge is awarded to a Scout who has completed the requirements for the merit badge.**

**1. Define the word:**

**2. Explain to your counselor the hardware you are most likely to encounter during automotive maintenance activities, and what you should do to maintain, help prevent, replace, or repair these hardware.**

**3. Discuss with your counselor the safety equipment, tools, and clothing used while checking or repairing a motor vehicle. Safety equipment:**

Workbook © Copyright 2012 by the Boy Scouts of America Service Project, Inc. All Rights Reserved  
 Reprinted by permission of the Boy Scouts of America Service Project, Inc.



Automotive Maintenance Workbook  
(free just click on the link)



# The Merit Badge Pamphlet & Workbook

## IMPORTANT NOTES!

1. This presentation does not replace the Merit Badge Pamphlet.

You Should Read the Merit Badge Pamphlet

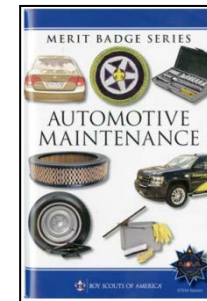

2. The Merit Badge workbook can help you complete your requirements but you still should Read the Merit Badge Pamphlet.

The work space provided for each requirement in the workbook should be used to make notes for discussing each item with your counselor, not for providing full and complete answers.

3. You must do each requirement to earn the Merit Badge.

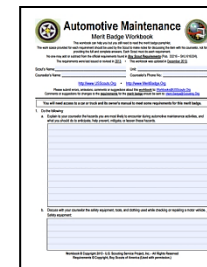



# Safety

## Basic Tools

Using the right tools when working on your car will make the job easier. An ASE (Automotive Service Excellence) certified technician typically has hundreds of common and specialty tools to work on a variety of vehicles. However, every auto owner should have some basic hand tools and safety equipment to perform periodic maintenance and minor repairs.

## Safety Equipment

When working on vehicles, think safety first. You should use the proper tools and clothing to protect yourself.

### Eye Protection

Eye Protection is a must when working on cars. Eyes are so fragile. Safety glasses and goggles will help prevent foreign materials from entering your eyes. These are especially important when inspecting the underbody of a vehicle and working around chemicals. Goggles can be used over prescription glasses.

### Ear Protection

Use earplugs or earmuffs when the work area is excessively loud. Noise with high decibel levels can damage your hearing.

### Gloves

Use work gloves when you are performing work on tires or exhaust. Extremely worn tires can have sharp steel belts poking from the tread. Exhaust systems can be hot and have rusty holes that can cut your hands. Use disposable latex gloves when you are working with chemicals, oils, and grease.





# Complete Requirement # 1

Do the following:

a. In your workbook or on a piece of paper explain to your counselor the hazards you are most likely to encounter during automotive maintenance activities, and what you should do to anticipate, help prevent, mitigate, or lessen these hazards.

Once completed arrange a meeting with your counselor

b. Discuss with your counselor the safety equipment, tools, and clothing used while checking or repairing a motor vehicle.





# That Marvelous Driving Machine

On June 4, 1896, Henry Ford took a short drive around his Detroit neighborhood on his experimental Quadricycle. This vehicle was little more than a frame, a seat, a small engine, a steering bar, and four bicycle wheels. With its 4-horsepower engine, the Quadricycle could reach a top speed of 20 miles per hour. By comparison, even the most basic cars today have 100-horsepower engines and can easily reach speeds of 100 miles per hour.

## Automobile Systems

Modern automobiles are complex machines. They are assembled from more than 15,000 parts, with more than 1,500 synchronized to move together. Learning how they work may appear impossible. In fact, just the opposite is true. The trick is to divide car operation into several systems. We will explain and describe each system individually, how these systems relate to each other, and the total operation of the car.



Ford Quadricycle 1896



Ford Fusion 2016





# That Marvelous Driving Machine



1909 Ford



1929 Ford Model A



1949 Ford Custom Convertible

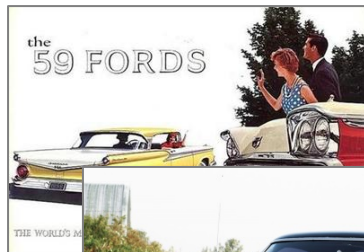

1969 Ford Mustang

## A System of Systems

It might seem impossible to understand how cars work, but just the opposite is true. The trick is to divide the car into several systems: the engine, the drive train, the lubrication system, etc. By learning how each system works by itself and with other systems, you can understand how the whole car functions. First, though, we will look at some important information about maintenance, registration, and safety, before moving onto the automobile's major systems.

### Horsepower

In technical terms, 1 horse power equals the power a horse would use to move 550 pounds of cargo a distance of 1 foot in 1 second. That's 745.7 watts of power.







# Maintenance, Registration and Inspection

## Routine Maintenance

In between scheduled maintenance visits that require more specialized service, you can take care of many maintenance tasks yourself, many of which will be explained later. For now, here is a quick list of tasks you should do regularly.

## Looking Under the Hood

Opening the hood on most cars is a three-step process. First, after putting the car in "park" and applying the parking brake, pull the hood-release handle inside the car. It is probably near the driver's seat or under the dashboard. Second, find and release the latch under the front edge of the hood. You may have to check your owner's manual for the location. Last hold the hood up with one hand and use the other hand to raise the hood support rod into place. (Some hoods stay up by themselves using springs or hydraulic cylinders.)

## Weekly Maintenance

Take time about once a week to do the following:

- Check the levels of oil, coolant, and windshield-washer fluid. Top off the fluids if necessary.
- Visually inspect the tires for damage or excessive wear. Use a tire pressure gauge to check for proper inflation.
- Visually inspect the wiper blades for damage.
- Check the battery terminals for corrosion. If there is corrosion, you will see a gray or white powder on the terminals.





# Maintenance, Registration and Inspection

## Monthly Maintenance

Every month or so, add the following to the weekly maintenance steps:

- Check the levels of transmission fluid, brake fluid, and power-steering fluid.
- If the battery is not sealed, check its water level. Refill with distilled water if necessary.
- Clean the battery terminals with a wire brush. Disconnect the terminals to break the electrical circuit, then clean the battery itself with a solution of baking soda and water.
- Inspect the spark plug wires, other electrical connections, hoses, and belts for damage and looseness.
- Wipe down door, trunk, and hood hinges. Apply white grease lubricant.
- Wash the exterior and vacuum the interior. Apply a commercial protectant to rubber, leather, and plastic surfaces such as vinyl tops, rubber door seals and tire sidewalls.



## Battery Tips

In many new cars, the battery powers such computer programming as the radio, clock, remote locks, and even wireless communication capabilities. If the battery power is cut off to these functions, it could mean expensive reprogramming by the car dealership. Check the owner's manual before disconnecting the battery for cleaning.



# Maintenance, Registration and Inspection

## Vehicle Registration and Inspection

Every state requires a vehicle's owner to register the vehicle before driving it on public streets. This process helps to ensure that the vehicle meets basic safety requirements, that the owner has liability insurance, and that the state knows who owns and operates the vehicle. The vehicle's owner must pay a fee, as well as a tax, to register the vehicle and receive license plates. Many states require annual vehicle inspections. Some inspections check for safety problems like defective brakes and burned-out headlights. Others include testing for excessive tailpipe emissions. In these states, vehicles must pass inspection in order to be registered. To learn about the laws that apply in our state, check the state's Web site. Make sure you have your parent's permission first.

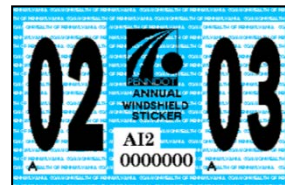



# Vehicle Safety

Cars and trucks can weigh up to 2 tons. They travel down the highway at speeds of 65 miles per hour or more. Often only a few feet separate moving vehicles. Therefore, vehicle safety is very important. Modern cars use both active and passive safety features to help protect their occupants.

## Active Restraints

**Safety belts** and child restraints are called **active restraints** because you must do something, such as buckling them, to make them work. When you use these features, you greatly increase your chances of surviving an accident. Passengers travel at the same speed as the car. If the car suddenly stops (such as when it hits another object), they will keep traveling at the original speed until something stops them. That could be the windshield, the dashboard, the road or a safety belt. If you are wearing a safety belt, you will slow down when the vehicle does. You will have more time to stop, you will stop over a longer distance, and your strongest bones, not the bones in your face, will absorb the force. That is why wearing safety belts makes such good sense. Most safety belts have two parts: a seat belt that goes across your lap and a shoulder belt that goes over your shoulder. Nearly all states require the driver and passengers to be buckled in all times.

**Child Car Seats** - Have you ever seen someone holding a baby while riding in a car? Think about this: In a crash at 25 miles per hour, a 12-pound baby would become a 240-pound force, almost impossible to hold onto. Fortunately, all 50 states require that babies ride in infant restraints. Use a rear-facing infant restraint in the back seat for babies who are under 1 year of age and under 20 pounds.

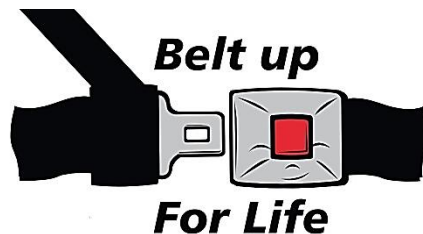





# Vehicle Safety

## Passive Restraints

All cars built today offer passive restraints. These are safety features that do not need the driver or passenger to do anything to make them work. The most common passive restraints are air bags. These devices stay in the steering wheel and dashboard until needed. They protect the driver and front-seat passenger. Air bags are required on all new passenger vehicles sold in the United States. Here is how an air bag works. If a front end crash occurs, sensors in the air bags notice that the car has suddenly slowed down or even stopped (a process called deceleration). This triggers a chemical reaction that fills the air bags with gas. In less than 1/20 of a second, the air bags balloon out, cushioning the driver and passenger. It is important to remember that air bags are supplemental restraints; they are designed to work with—not instead of—safety belts. Because air bags can open with lots of force, infants and children under age 13 should always ride in the back seat.







# Vehicle Safety

## Safety on the Road

Accidents do happen. which is why drivers need to be prepared. Just as you carry the Outdoor Essentials on camping trips. you should carry an emergency kit in your car

### Include these items:

- Jumper cables
- Spare fuses
- Two quarts of oil
- A gallon of coolant
- Aerosol tire inflator
- Two roadside flares
- A first-aid kit
- A "help" sign
- An ice scraper
- A multipurpose tool
- A flashlight
- Rags or paper towels
- A blanket
- Food and water
- A pen and paper



### Stay Safe While Working on Cars

Exercise caution at all times. A car's engine, cooling system, and drive train components get very hot, as do their fluids. It is a good idea to always wear gloves and safety glasses. You should also wear old clothing because you will be working with oils, lubricants, and other fluids. Never go under a vehicle that is not properly braced with a jack stand. When working in the engine compartment, disconnect the negative battery cable. This cuts off power to all the car's systems, so you will not get a shock or accidentally damage electrical components. It also prevents the electric cooling fan from coming on without warning and hurting you.



# Complete Requirement # 2



## General Maintenance, Safety, and Registration.

Do the following: a, g, h, and i. **Once completed arrange a meeting with your counselor for some “HANDS ON” activities.**

a. Review the maintenance chart in the owner's manual. Explain the requirements and time limits.

b. **With your counselor** demonstrate how to check the following:

1. [Brake Fluid](#)
2. [Engine Oil](#)
3. [Coolant](#)
4. [Power steering fluid](#)
5. [Windshield washer fluid](#)
6. [Transmission fluid](#)
7. [Battery fluid](#) (if possible) and condition of the battery terminals

Arrange a meeting with your counselor for some “hands on” activities.

c. **With your counselor** locate the fuse boxes; determine the size of fuses. [Demonstrate the proper replacement of burned-out fuses.](#)

d. **With your counselor** demonstrate how to check the condition and tension of [belts](#) and [hoses](#).

e. **With your counselor** check the lighting in the vehicle, including [instrument](#), warning, and [exterior bulbs](#).

f. **With your counselor** locate and [check the air filter](#).

g. Explain the purpose, importance, and limitations of [safety belts](#) and [passive restraints](#).

h. Find out the requirements for the [state inspection](#) in your state, including how often a vehicle needs to be inspected.

i. Explain the importance of registering a vehicle and find out the [annual registration fee](#) for renewing your family car's registration.



# The Dashboard

The dashboard is designed to keep you informed about the health of your vehicle. Dashboard indicator lights give you the insight you need to understand what is going on with your car. From your check engine light to your oil pressure light, the information you need to understand why that light might be on...even if it's because you've accidentally left your door open or your parking brake on.



Vehicle manufacturers provide dashboard gauges to give drivers important information about their vehicle. A dashboard gauge can show when a problem exists. If we know what they are telling us, these gauges can also let us know before a problem occurs. Typical dashboard gauges include Tachometer, Speedometer, Fuel, Oil Pressure, and Water Temperature





# Complete Requirement # 3

## Dashboard

Do the following:

- a. In your workbook or on a piece of paper explain the function of the [fuel gauge](#), [speedometer](#), [tachometer](#), [oil pressure](#), and [engine temperature gauge](#). Point out each one on the instrument cluster.
- b. In your workbook or on a piece of paper explain the [symbols that light up on the dashboard](#) and the difference between the yellow and red symbols. Explain each of the indicators on the dashboard, using the owner's manual, if necessary.

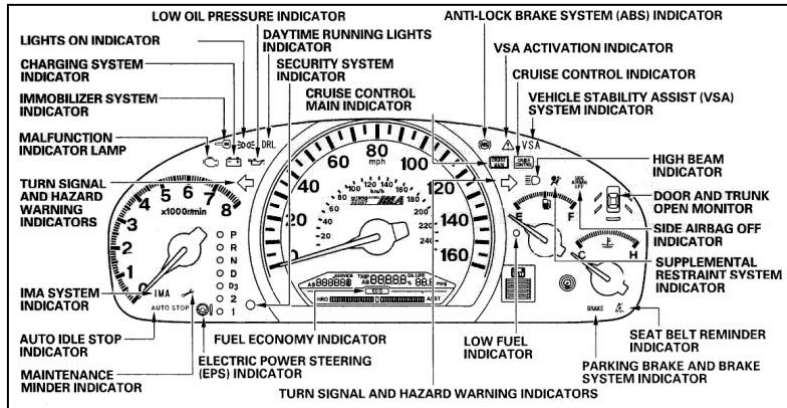

Once completed arrange a meeting with your counselor



# Wheels and Tires

Wheels and tires go together like peanut butter and jelly. While we could make car wheels that did not need tires, the ride would be very rough. (Imagine being pulled along in a child's wagon at 65 miles per hour!) Tires help soften the ride and grip the road, even when the road is covered with rain, snow, or mud.

## Wheel Design

Most wheels are made of stamped steel. Others are made of cast aluminum, which is stronger and can be made in different designs for a special look. Four or five lug nuts connect the wheel to the axle shaft.

## Tire Design

Every tire has three main parts: the tread, the sidewalls, and the beads. The *tread* is the part that touches the road. Its grooves are paths for water to run off, which improves *traction* (grip). The *sidewalls* are between the tread and the wheel rim. These smooth, flexible sections absorb shocks and cushion the ride. They also create a space that holds air. The sidewalls end at the *beads*, sturdy steel rings that hold the tire to the rim.



## Disposing of Old Tires

Tires eventually wear out. They must be disposed of properly. Ask a local tire dealer about local rules for getting rid of old tires. Today millions of tires are recycled every year. They become things like playground mulch, patio decking, and even artificial reefs.





# Wheels and Tires

## Inside the Tire

The interior of the tire is strengthened with several layers or plies, of rubber-coated fabric cord. In most car tires, called radial-ply tires, these cords run at (or near) a right angle to the center of the tire. These tires stay cooler, have a softer ride, and have a longer tread life. Two older kinds of tires are bias-ply tires, which have cords set at an angle of about 40 degrees, and bias-belted tires, which have both crisscross layers (like bias-ply tires) and tread reinforcing belts (like radial tires). Most radial tires have steel belts, which is why they are often called steel belted radials. The belts help the tires resist punctures and help flatten the tread, which improves traction. **Watch the Video:** [How Tires are Made](#)

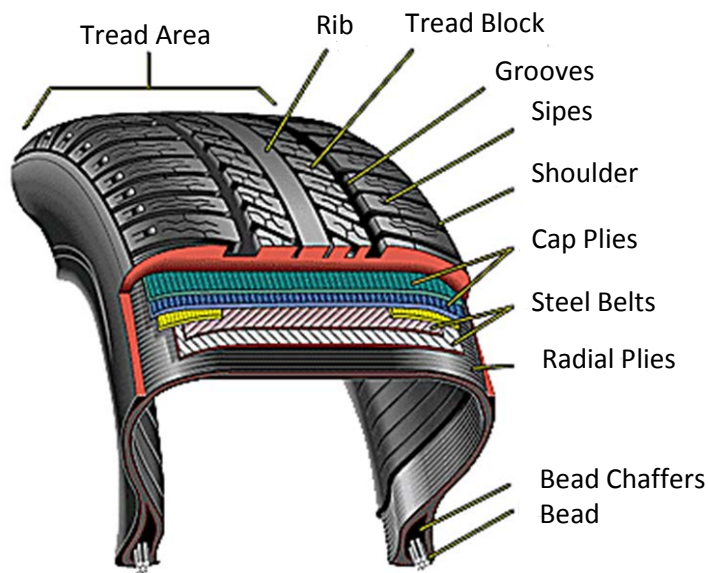

## Tire Wear Indicators

Many tires have wear indicators in the tread. When only about 1/16 of an inch of tread is left, you can see a band running from one side of the tire to the other. This means the tire is near the end of its useful life. **Watch the Video:** [Tire Wear Indicator](#)





# Wheels and Tires

## Tire Specifications

The sign on the driver-side door or doorjamb (or inside the glove box or engine compartment) tells you the proper tire size, inflation pressure, and sequence for rotating tires. Tires can also tell you a lot of information about themselves.

## Tire Size and Inflation

A typical passenger tire size is P215/65R 15. These letters and numbers are a code. Here is what that code tells you:

- P stands for passenger:
- 215 means the tire's width is 215 millimeters.
- 65 means the tire's height is 65 percent of its width (the aspect ratio).
- R stands for radial-ply.
- 15 means the wheel's diameter is 15 inches.

You will find a tire's size on its sidewall, along with some other information:

- The maximum allowable inflation pressure in pounds per square inch
- The tire's load index and speed rating
- The tire's maximum load rating
- Information about the tire's construction
- The tire's grades for tread wear, traction, and temperature

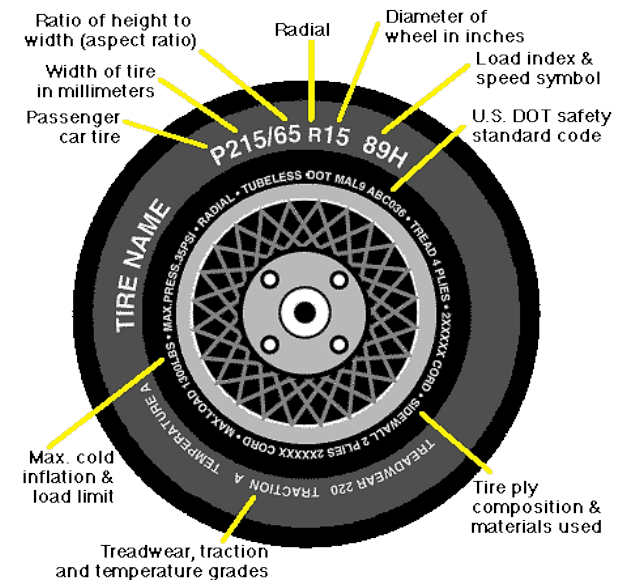



# Wheels and Tires

## Tire Rotation

Tires tend to wear unevenly, both front to rear and side to side. To make them last longer, manufacturers recommend that you regularly move them from wheel to wheel. This is called rotating the tires. (Include the spare). Typically, you should rotate new tires after the first 7,500 miles and then every 15,000 miles.

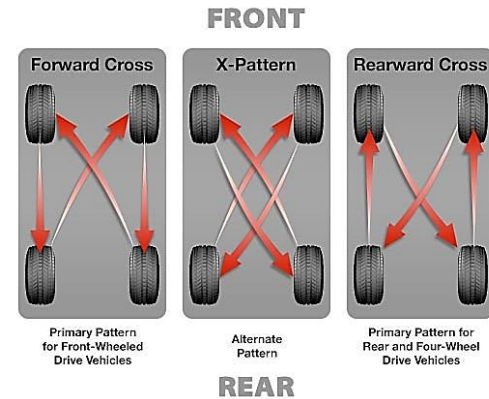

## Wheel Alignment and Tire Wear

Wheels may look like they are set straight up and down, but they are actually set at slight angles to help improve vehicle handling and tire life. It is important to keep wheels aligned; misaligned wheels will shorten the life of your tires.

## Camber

Camber is the inward or outward tilt of the wheel, as seen from the front of the vehicle. It is measured in degrees between vertical and the tire's centerline. Inward tilt is negative camber. Outward tilt is positive camber.

Watch the Video: [Camber](#)



Negative Camber



Positive Camber



# Wheels and Tires

## Caster

Caster is the angle that the steering axis is offset from the vertical, as viewed from the side. It increases directional stability, such as when the car is on an unstable surface (rough or slick, for instance). (That is why the fork on a bicycle connects at an angle to the hub of the front wheel.) Caster is measured in degrees. Backward tilt is positive caster. Forward tilt is negative caster.

Watch the Video: [Caster](#)

## Toe-In / Toe-Out

Toeing is measured in fractions of an inch. It affects how evenly the tires will wear. A wheel's toe measurement is the difference in the distance between the front edges and the back edges of a pair of tires. Toe-in means the front edges of the tires are closer together. Toe-out means they are farther apart.

Watch the Video: [Toe-In / Toe-Out](#)

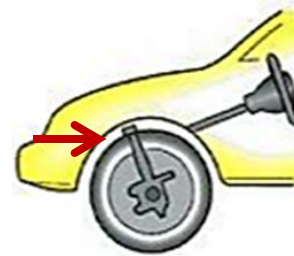

Negative Caster



Positive Caster



Toe-in



Toe-out

## Air Pressure

You should check the pressure of all tires, including the spare tire, once a month. Add air as needed with an air hose. You can use a handheld tire gauge. (The round ones are more accurate than the pen-shaped ones.) You can also use the gauge that is part of the air hose.



# Wheels and Tires

## How to Change a Tire

Road hazards like nails and broken glass can puncture a tire's tread. When that happens, you need to be able to change the tire. In most cars, you will find the spare tire under the floor of the trunk. A jack and lug wrench should also be there. Before you begin, put the transmission in park (or in gear if it is a manual transmission), and apply the parking brake. Have the spare tire, jack, and lug wrench handy. Then follow these key steps in changing a tire.

**Step 1** - Stabilize (chock) the wheel that is diagonally opposite the flat tire by putting bricks, logs, or other heavy objects in front of and behind it.

**Step 2** - Pry off the wheel cover or hub ornament with the narrowed end of the Jug wrench.

**Step 3** - Loosen, but do not take off, the lug nuts with the wrench. You may have to step on the end of the lug wrench to make it turn.

**Step 4** - Find the notch under the door panel nearest the flat tire, and center the jack there. Turn the handle of the jack clockwise until the wheel is all the way off the ground.

**Step 5** - Remove the Jug nuts and put them in a safe place. such as inside the wheel cover. Then, pull the wheel off the vehicle.

**Step 6** - Put on the new wheel and tire.

**Step 7** - Put the lug nuts back on with the tapered edges facing inward; hand-tighten them.

**Step 8** - Lower the vehicle by turning the jack handle

**Step 9** - Tighten the lug nuts all the way, following the order in the picture. Put the wheel cover or hub ornament back on. Put the jack and lug wrench back in the trunk, along with the flat tire. Get the flat tire fixed as soon as possible.

Watch the Video: [How to change a tire](#)

### Did You Know

Most new cars sold today do not come with a spare tire. Most new cars come with a "Roadside Assistance" package that handles roadside flat tires.





# Complete Requirement # 4

## Wheels & Tires

Do the following:

- a. In your workbook or on a piece of paper explain the difference between tire manufacturer's and vehicle manufacturer's specifications and show where to find them.
- b. **With your counselor** demonstrate how to [check pressure and properly inflate](#) a tire. [Check the spare tire](#) and make sure it is ready for use.
- c. In your workbook or on a piece of paper explain why wheel alignment is important to the life of a tire. [Explain camber, caster, and toe-in adjustments](#) on wheel alignment.
- d. In your workbook or on a piece of paper explain the purpose of the [lateral-wear bar indicator](#).
- e. In your workbook or on a piece of paper explain how to dispose of old tires in accordance with [local laws and regulations](#).

Once completed arrange a meeting with your counselor to do item b.



# The Engine

The engine is the single most important part of an automobile. It burns fuel to create heat and then converts that heat into mechanical motion, which makes the wheels go round and makes the accessories work.

## Types of Engines

For many years nearly all cars and trucks had either gasoline engines or diesel engines. Both engine types rely on combustion which means that the fuel is burned inside the engine. More recently gas-electric hybrid engines have appeared. These vehicles have engines that are more fuel-efficient than traditional engines. Automakers are now testing hydrogen fuel-cell vehicles. During your lifetime, other kinds of engines may become common.

## Gasoline Engines

To understand how a gasoline engine works think about a bicycle. When you pedal a bicycle your body burns the calories from the food you have eaten. This creates the energy your muscles need to move your legs up and down. The bicycle's pedal system changes this movement into circular (rotary) motion and sends the motion to the rear wheel through a connecting chain and sprocket. In a gasoline engine, the "legs" are pistons. Pistons are shafts that slide up and down within tubes called cylinders. A mixture of fuel and air enters the combustion chamber (the space inside the cylinder), where a spark ignites it. This causes a controlled explosion (a release of chemical energy) that pushes the piston down inside the chamber. A connecting rod and crankshaft (convert this up-and-down motion (mechanical energy) into rotary motion. A series of shafts and gears then sends this motion to the wheels of the vehicle and makes them turn.

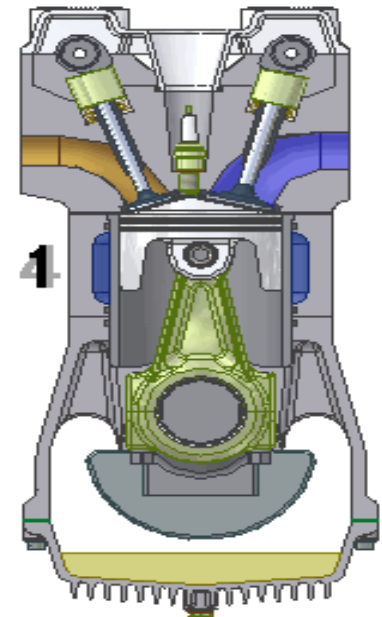



# The Engine

## Piston Engines

Most car engines have four, six, or eight cylinders of the same size. In general, the more cylinders an engine has, the more powerful it is. The cylinders can be arranged in several ways (called configurations), including inline (or straight), V, and opposed (or boxer).



Inline 4 Cylinder

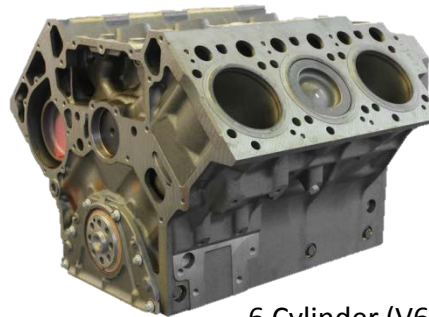

6 Cylinder (V6)



8 Cylinder (V8)

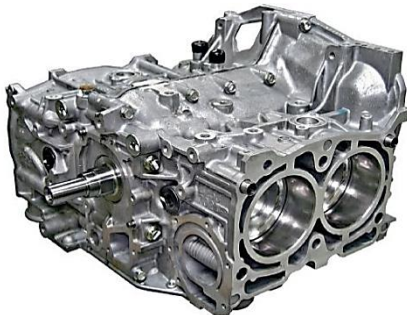

4 Cylinder Boxer

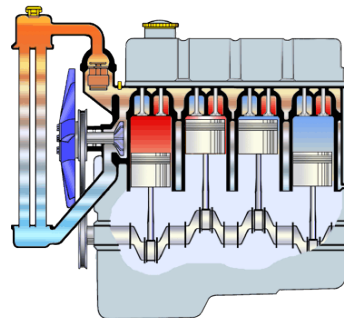

Diesel Engine

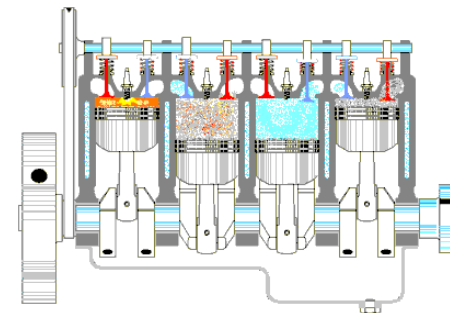

Gasoline Engine



# The Engine

## Four-Stroke Cycle

It takes four steps, or strokes, for a piston to create energy.

**Intake Stroke.** The intake valve opens, and the piston moves down in the cylinder. This pulls in an air-fuel mixture and makes the crankshaft spin. Then the intake valve closes.

**Compression Stroke.** When both valves are closed, the spinning crankshaft pushes the connecting rod, which forces the piston up. The piston squeezes the air-fuel mixture in the combustion chamber. This heats up the air-fuel mixture and raises its pressure, making it burn more easily and quickly and produce more energy.

**Power Stroke.** As the piston reaches the top of its stroke and a spark plug ignites the compressed mixture. In about two thousandths of a second, the mixture burns. The gases expand, pushing the piston downward. As the piston moves downward, the connecting rod moves downward, too, and turns the crankshaft, which powers the engine.

**Exhaust Stroke** The exhaust valve opens as the connecting rod pushes the piston upward. The piston forces the burned gases out of the combustion chamber through the exhaust valve. At the top of the stroke, the exhaust valve closes. The cylinder is now ready for the next intake stroke.

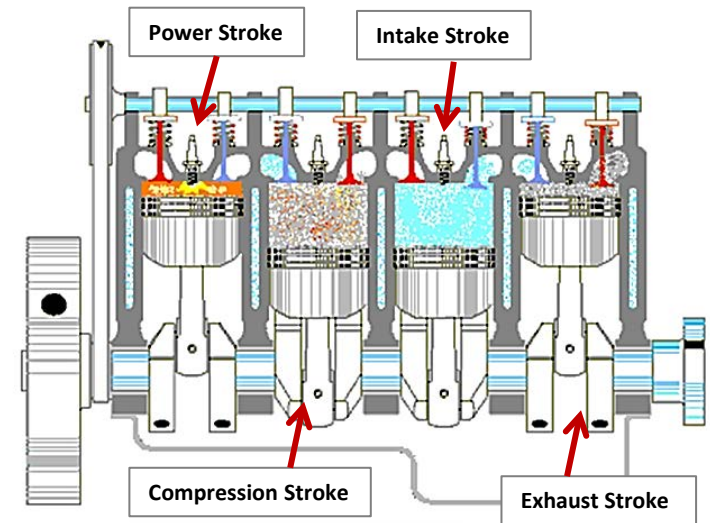

Click on the engine to watch the video

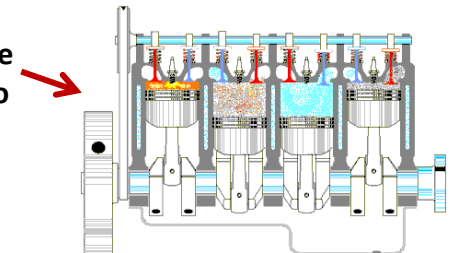

Everything just described happens very quickly. Depending on the car's speed and acceleration (how quickly it gains speed), the crankshaft may rotate between about 700 and 7,000 revolutions per minute (RPM)!



# The Engine

## The Valve Train

As you might imagine a simple four-stroke cycle would produce a jerky motion. Because only one stroke would produce power. That is why, in a modern engine, different cylinders are always on different strokes. At any point, one cylinder will be on the intake stroke, one will be on the compression stroke, etc. A heavy spinning weight called a flywheel at the rear of the engine provides energy (momentum) to help keep the crankshaft turning. The parts of the valve train work together to open and close the valves at just the right moment. The key part is the camshaft, which connects to the crankshaft with gears or a chain. As the camshaft rotates, egg-shaped parts called cams open the valves in the right order. (Springs on the valves close them.) Modern engines have overhead cams. This means the camshaft is above the valves, not below them near the crankshaft. Some more powerful engines have dual overhead cams (DOHCs). On these engines, there are two intake and two exhaust valves per cylinder.

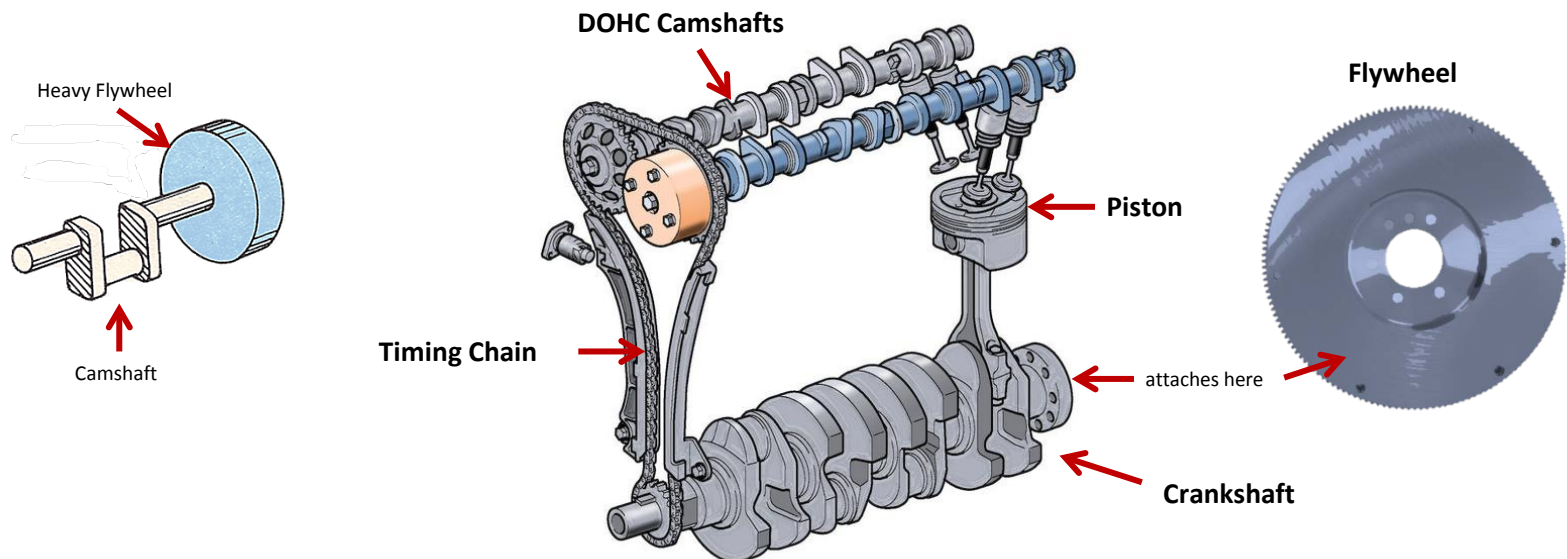





# The Engine

## Understanding Diesel Engines

In many ways, diesel engines are like gasoline engines. They belong to the internal combustion family and share many features. They use a different fuel, however, and the air-fuel mixture is not ignited by a spark plug. Instead, the engine uses compression ignition. This means that the intake stroke draws air into the cylinder by itself. The piston compresses it to a much higher pressure than in a gasoline engine. An injector then sprays fuel into the chamber, and the fuel ignites.

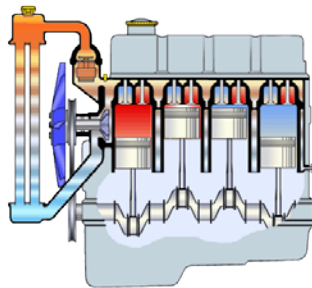

**Diesel Engine**

Note: No spark plugs

## Gasoline-Electric Hybrid Vehicles

Strictly speaking, a hybrid vehicle is any vehicle that uses more than one source of power. Mopeds are one example. They combine the power of a gasoline engine with the rider's pedaling power. Locomotives are another example. They are typically diesel-electric hybrids. In the late 1990s, automakers began introducing gas-electric hybrid cars. A gas-electric hybrid car has a gasoline engine that is like (but smarter than) a typical car engine. It also has an electric motor that helps power the car and its accessories, such as power steering and air-conditioning. When the driver applies the brake, the energy that is created recharges the battery.

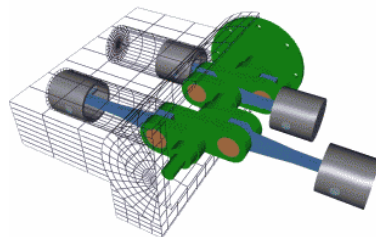

**Boxer Engine**

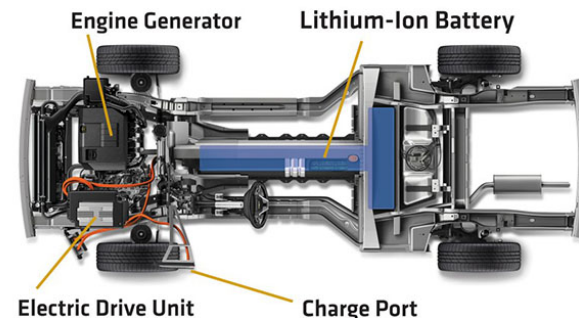



# Complete Requirement # 5

## Engine

Do the following:

- In your workbook or on a piece of paper explain how an [internal combustion engine](#) operates. Tell the differences between [gasoline](#) and [diesel](#) engines. Explain how a [gasoline-electric hybrid](#) vehicle is powered.
- In your workbook or on a piece of paper explain the purpose of engine oil. [Explain the API service code, the SAE number, and the viscosity rating.](#)
- In your workbook or on a piece of paper explain where to find the recommended oil type and the amount of oil to be used in the vehicle's engine.

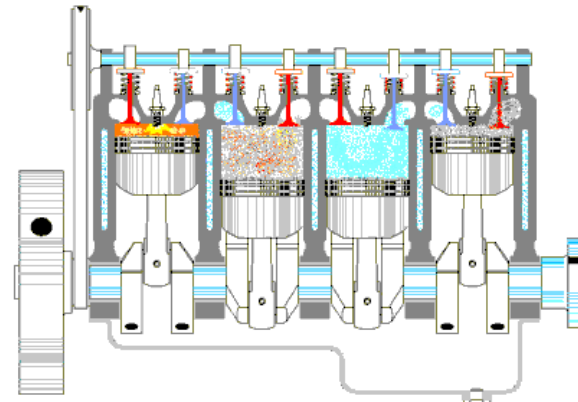
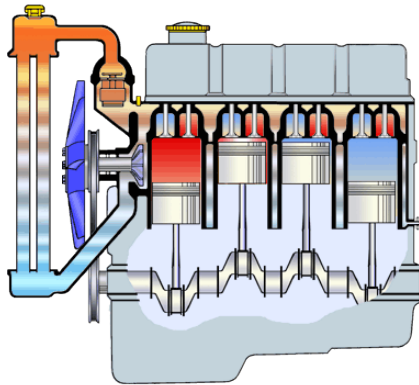

Once completed arrange a meeting with your counselor



# The Lubrication System

When pistons and other engine parts move, they make friction and heat. Oil reduces the friction and carries away the heat. It also reduces corrosion and works as a seal to keep combustion gases from passing between the piston and cylinder walls.

## How Oil Circulates Through the Engine

Engine oil goes in a pan at the bottom of the engine. This pan is called the crankcase because the crankshaft rotates in it and splashes oil on various surfaces. An oil pump forces the oil through all parts of the engine. Gravity makes the oil return to the crankcase. As the oil flows through the engine, it passes through an oil filter, which takes out rough particles the oil has picked up. Most filters are made of paper that is soaked in resin and folded like an accordion.

## Types of Oil

Different engines and different operating conditions need different types of oil. The Society of Automotive Engineers and the American Petroleum Institute have codes that define various oil types. The API service code tells you when to use that kind of oil. This two-letter code starts with S for gasoline engines and C for diesel engines. The second letter tells you the general quality level. Letters nearer the end of the alphabet mean higher quality. For example, SM (the standard as of 2004) is better than SL. Diesel service codes have a number at the end to indicate a four-stroke or two-stroke engine: CJ-4 (the standard as of 2006) is for four-stroke engines. If an oil works in both gasoline and diesel engines, it will have a code like SM/CJ-4. The SAE number tells you the oil's viscosity rating. Which measures how easily the oil flows. When oil is cold, it gets heavy and thick like pancake syrup. When it is hot, oil is light-colored and runny like water. Manufacturers measure an oil's viscosity when it is cold and give it a number like 10W. (W stands for winter.) The lower the number, the more easily the oil flows. Most cars today need multiple viscosity oil, which is made to be thin at low temperatures and thicker at high temperatures. This type of oil has a code such as SAE 5W-30. The 5W tells you the viscosity when cold. The 30 tells you the viscosity when the engine reaches operating temperature (generally about 200 degrees Fahrenheit).

**Watch the Video:**  
[Motor Oil Understanding The Numbers](#)

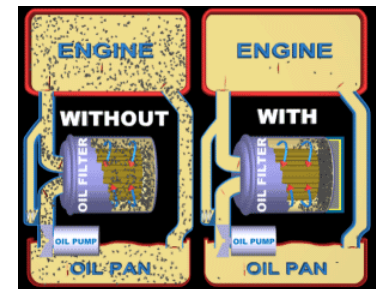

**Watch the Video:**  
[How Engine Lubrication System Works](#)



# The Lubrication System

## Checking and Adding Oil

Each vehicle's owner's manual states the type and amount of oil the vehicle needs. It also says how often you should change the oil and filter. A standard interval is every three months or 3,000 miles, although some auto manufacturers suggest longer intervals. **Watch the Video:** [How To Check Your Engine Oil Level](#)

## Changing the Oil

Before you begin to change your car's oil, check the owner's manual to determine the types and/or sizes you need of the following materials.

- 6 quarts of the type of engine oil suggested in the owner's manual
- 1 oil filter
- oil pan suitable for disposing of the used oil

If you have never changed the oil on a car before, it is best to have an experienced adult help you. Before you begin, put the transmission in park (or in gear if it is a manual transmission), and apply the parking brake. Use car jacks, much as you would to change the tire, to lift the car off the ground far enough for you to slide beneath it. **Watch the Video:** [Changing Your Oil](#)

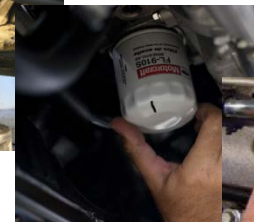
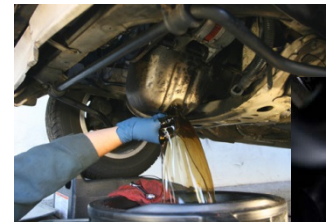



# The Cooling System

Gasoline burns at temperatures as high as 4,500 degrees Fahrenheit, so a gas engine makes large amounts of heat. Only about 25 percent of this heat is used to create power. About 35 percent passes out of the exhaust system into the air, and 10 percent is lost to internal friction and lubrication. The cooling system carries away the remaining 30 percent of heat. If the cooling system fails, engine oil evaporates, and parts can lock up or even melt, damaging or even destroying the engine.

## How the Cooling System Works

A belt-driven water pump at the front of the engine circulates *coolant* (a mixture of water and antifreeze) through water passages inside the engine block and cylinder head. This transfers heat from the metal to the liquid coolant. The coolant then passes through tubes in the radiator. Thin metal fins attached to the tubes give the tubes much more surface area, which helps speed the cooling process. The fins conduct heat away from the coolant and into the passing stream of air. When the vehicle is standing still or moving slowly, a fan blade helps pull air through the radiator.

Watch the Video: [How a Car Cooling System Works](#)

## Coolant Temperature Control

When you first start a vehicle, there is no need for cooling. The engine must come up to operating temperature as fast as possible to ensure maximum performance, good oil flow, and in wintertime, heat for the passengers. When the engine is cold, the thermostat closes, blocking coolant flow through the radiator. Coolant can circulate only through the engine. When the engine coolant temperature rises to above 195 degrees, the thermostat valve opens and coolant flows through it from the engine to the radiator.

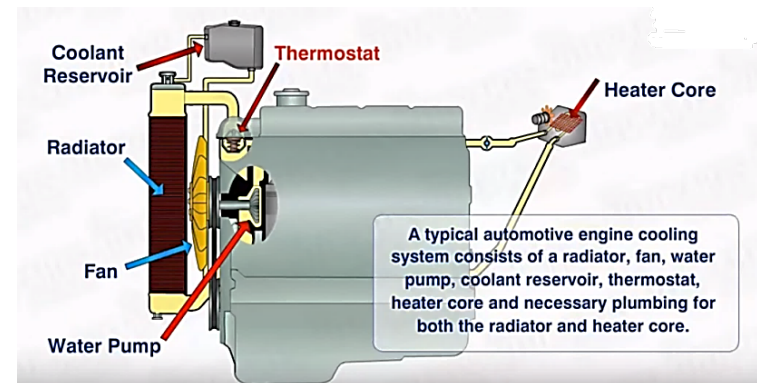





# The Cooling System

## Pressurized Radiator Cap

To provide efficient cooling, a special radiator cap pressurizes the system and increases the coolant's boiling point to more than 250 degrees Fahrenheit. **Never unscrew or remove the radiator cap when the engine is hot.** The hot coolant can spray out and cause severe burns.

It bears repeating: **Never unscrew the radiator cap when the engine is hot.**

## Coolant

Manufacturers generally recommend an equal mixture of water and ethylene-glycol antifreeze. This coolant mixture offers good cooling during the summer and protects the engine down to about 35 degrees below zero Fahrenheit in the winter. Some manufacturers now sell pre-diluted coolant. When you use this type of coolant, you should not add water.

## Cooling System Maintenance

Coolant should be checked regularly and replaced about every 30,000 miles. The system also might need to be flushed if there is too much dirt and rust in the coolant. To check the car's coolant in most new cars, you need only to check the coolant level on the plastic coolant reservoir and, if necessary, add coolant there. If your car does not have one of these reservoirs, you will need to remove the radiator cap to check the fluid- **but only if the engine is cool!** To remove the cap, wrap a cloth around the cap and slowly loosen it to the first stop. Step back and let the pressure release. Then, with the cloth still in place, press down and slowly turn the cap until it is free.



Watch the Video:  
[Checking coolant for beginners](#)

Watch the Video:  
[How to do a Coolant Flush](#)



# Complete Requirement # 6

## Cooling System

Do the following:

- Explain the need for coolant in the cooling system.
- Explain how to [flush and change the engine coolant](#) in the vehicle, and how to properly dispose of the used coolant.

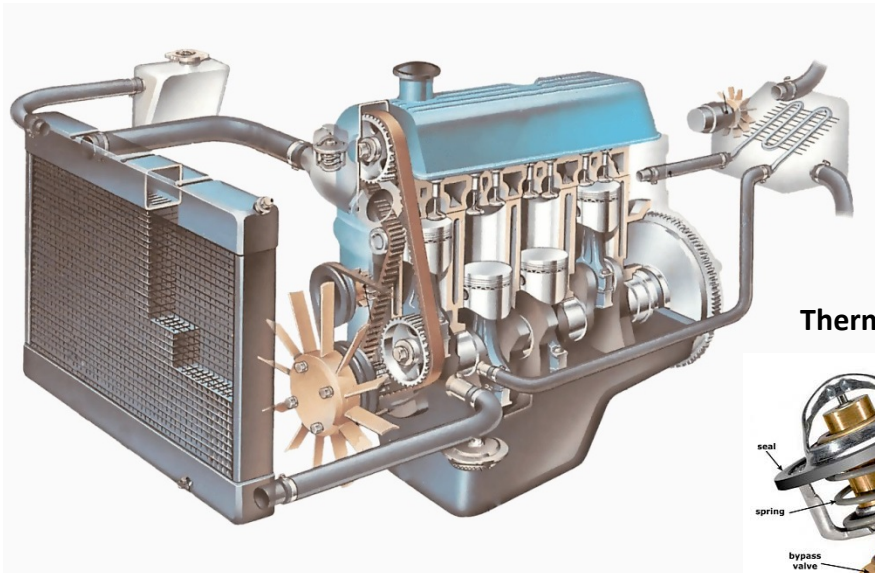

Thermostat

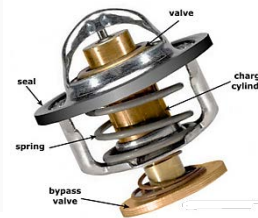

Water Pump

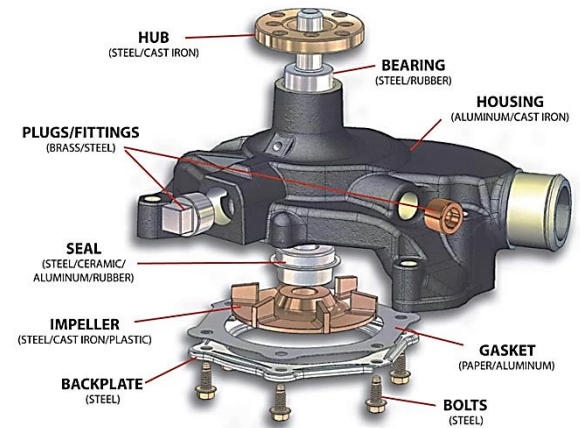



# The Air Intake and Fuel Systems

## The Air Intake and Fuel Systems

As mentioned earlier, automobile engines burn a mixture of fuel and air. The air intake and fuel systems work together to create this mixture.

### Operating Principles

The air intake and fuel systems use many different devices and sub systems, including a computer called the engine control unit, to make sure the engine uses the right mixture of air and fuel. These systems may seem complex, but they rely on three basic principles: air-fuel mixture, pressure, and gasoline vaporization.

### Air-Fuel Mixture

The combustion process creates power by burning a mixture of air and gasoline. The amounts of each, however, change all the time because of differences in temperature, vehicle speed and terrain. The engine burns fuel best, with the most complete combustion and the lowest emissions, when it mixes 14.7 parts of air with one part of gasoline. This is written as 14.7:1 and is called the air-fuel ratio. (Because the engine needs such a precise ratio, the actual ratio is computer-controlled.)

The car may need a rich mixture, with less air and relatively more fuel (like a ratio of 8.0:1), when starting on a cold morning or when speeding up to pass another vehicle. Different air-fuel ratios are required for different operating conditions. A lean mixture, with more air and relatively less fuel (like a ratio of 17.0:1), may be all the car needs to cruise at low speed with a warm engine.

### Vacuum and Pressure Relationships

Air inside a balloon is under much higher pressure than air outside. That is why the air will rush out of a balloon if you do not tie the end. The same principle is at work inside a car engine. As the piston moves downward it leaves a vacant space of low pressure called a *vacuum*. Air rushes in to fill the space. As this airstream flows into the engine, the engine takes in gasoline to create the combustible air-fuel mixture.



# The Air Intake and Fuel Systems

## Preparing Gasoline for Combustion

Liquid gasoline will not burn. When you see flames above a pool of gasoline, you are really seeing gasoline vapors on fire. Turning liquid gasoline into flammable vapors (called atomization) is one of the main functions of the fuel system. It does this by spraying droplets of fuel into the airstream. This is similar to the way a spray bottle works. These tiny droplets of gasoline heat up and vaporize just before they go into the combustion chamber.

## Intake System

Engines use lots of air. Remember the 14.7:1 air-fuel ratio? It describes the amounts by weight. Because air is lighter than gasoline the average engine uses about 9,000 gallons of air for each gallon of gasoline! Air enters the engine through the air intake system at an inlet tube, passes through an air filler, enters an intake manifold, and then passes through an intake valve into a combustion chamber. Besides pulling air into the engine, the air intake system also filters dust and fine particles from the airstream. These things can cause serious damage inside the engine due to abrasion or plugged passageways. Most engines use a paper filter to clean the incoming air. The filter is inside an air cleaner assembly, typically located in a rectangular box at the side of the engine.

## Air Filter Maintenance

The air filter traps debris (waste) in the paper. Eventually the small pores of the paper plug up. You should check the filter from time to time and replace it if there is too much debris. Refer to the owner's manual for the recommended replacement interval (typically 30,000 miles) and step-by-step instructions.

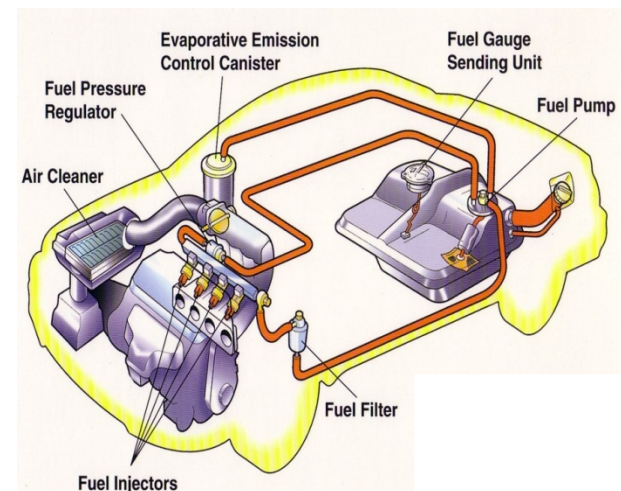



# The Air Intake and Fuel Systems

## The Fuel System

Metering is the process of measuring gasoline and delivering it to the engine. A car can use one of two methods to meter gasoline: carburetion and fuel injection. Carburetion relies on the vacuum that incoming air creates to add fuel to the engine. Fuel injection uses computer-controlled jets to atomize fuel and pump it into the cylinders. Fuel injection is more efficient than carburetion and creates less pollution. All cars sold in the United States since about 1990 have used fuel injection.

## Fuel Injection

Fuel injectors are computer-controlled valves that shoot precise amounts of atomized fuel into the engine. When you press the accelerator, a throttle valve opens and lets air into the engine. (The gas pedal should really be called the air pedal!) The engine control unit senses this action and turns on the fuel injectors.

How much fuel does the engine need? This depends on many factors, including engine speed, engine load, barometric pressure, airflow, coolant temperature, throttle valve angle, and exhaust oxygen content. Based on these factors, the engine control unit decides how long to keep each injector open (the pulse width) and exactly when to inject the fuel so it will happen when the piston is on the intake stroke.

The injectors may be located in the throttle body itself or in the intake manifold near each cylinder:

- In throttle-body fuel injection, one or two injectors add fuel to the air before it reaches the cylinders.
- In multiport fuel injection, there is an injector near each cylinder. Half the injectors fire at a time.
- In sequential fuel injection, an injector near each cylinder fires just before the cylinder opens. Most cars sold in the United States today use sequential fuel injection.

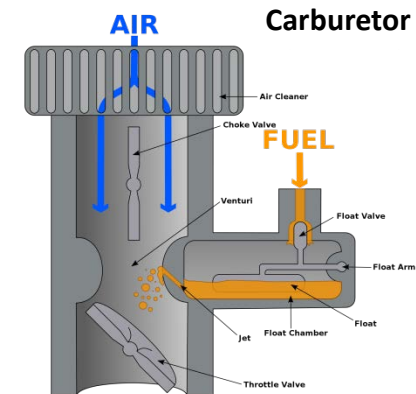

Watch the Video: [Carburetor vs Fuel Injection](#)

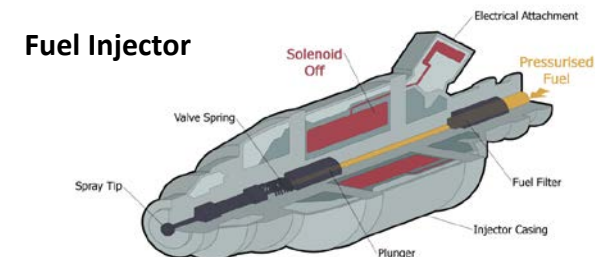





# The Air Intake and Fuel Systems

## The Fuel Tank and Fuel Delivery System

The fuel tank is at the rear of the vehicle. Fuel leaves it through a device called a fuel pickup, which is covered with a finely woven fabric or metal screen that traps large particles of dirt, rust, scale, and moisture. It seldom requires replacement. A fuel pump forces fuel through metal tubing to the fuel injection system. The pump is usually inside the fuel tank. A second fuel filter is either on the top of the fuel pump module /pressure regulator assembly or in the fuel line. If this filter is outside the fuel tank, it may be either under the car or in the engine compartment. The filter element may be made of pleated paper or some other material.

## Fuel Filter Maintenance

The inline filter traps very small pieces of debris so they do not plug fuel system passages. Some of these pieces are smaller than the diameter of a human hair. Most newer vehicles do not specify how often to check fuel filters. Use common sense. If the engine seems to be starving for fuel, check the filter. Replace the filter if it is dirty.

## Fuel Additives

After crude oil is refined into gasoline, producers add compounds (different kinds of chemicals) to make it a better fuel. These include inhibitors, which keep the system clean by controlling sticky deposits and slowing corrosion (rust), and detergents, which keep deposits from building up. (This is important in fuel-injected engines, which have very small openings.) In winter, manufacturers may add alcohol, which keeps gas lines from freezing. Because of local emission laws, some states require manufacturers to sell winter and summer blends of fuels according to the season. For many years, manufacturers added lead to prevent a pinging sound made during acceleration and to lubricate valves. However, lead is a health hazard and also can hurt a car's catalytic converter (a device that reduces exhaust emissions). Today U.S. gas stations sell only unleaded gasoline. Gasoline manufacturers use other additives to prevent pinging.

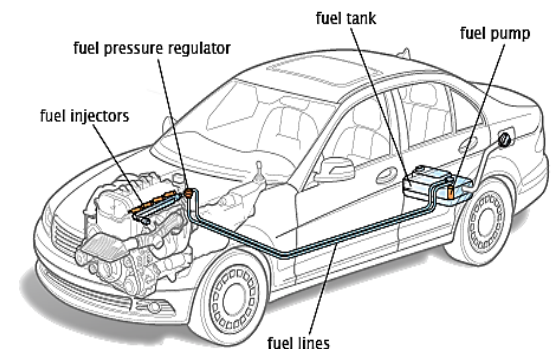



# Complete Requirement # 7



## Air Intake & Fuel system

Do the following:

- Explain how the air and fuel systems work together and why it is necessary to have an air filter and fuel filter. How the air and fuel systems work together. Why it is necessary to have an air filter. Why it is necessary to have a fuel filter.
- Explain [how a fuel injection system works](#) and how an [on-board computer works](#) with the fuel injection system.

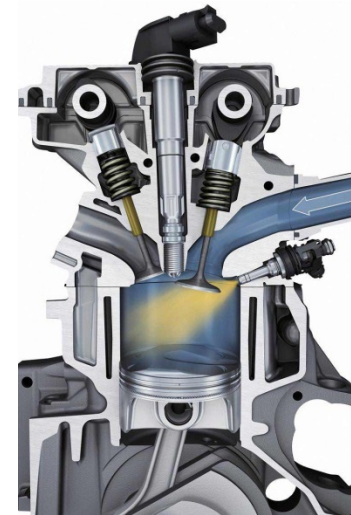

Once completed arrange a meeting with your counselor



# The Ignition and Electrical Systems

The engine gives a car most of its power, but electricity makes the car start, fires the spark plugs, and runs such features as the headlights and the sound system. The ignition system uses electrical power to make a spark in the combustion chamber, which ignites the air-fuel mixture. The battery provides the power to start the engine. While the engine is running, the charging system keeps the battery charged. When the engine is off, the battery sends electricity to the lights, sound system, and other electrical systems.

## The Ignition System

The ignition system creates the sparks that make the cylinders fire. The most important part of this system is the spark plug at the top of each cylinder, which has a gap in it. When there is enough electrical power (as much as 40,000 to 50,000 volts), electricity jumps this gap. This causes an arcing effect that makes the air-fuel mixture in the cylinder explode.

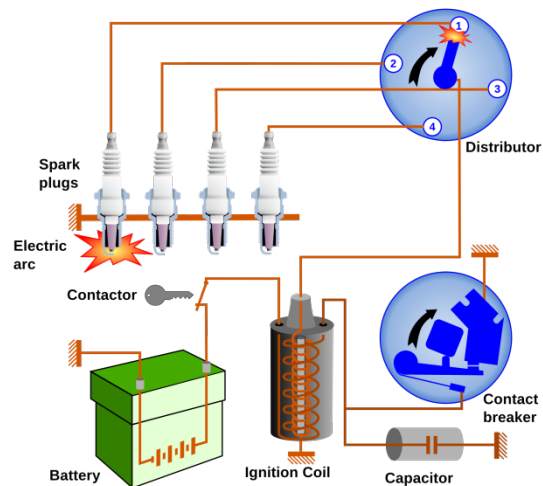

Watch the Video:  
[How Ignition System Works](#)

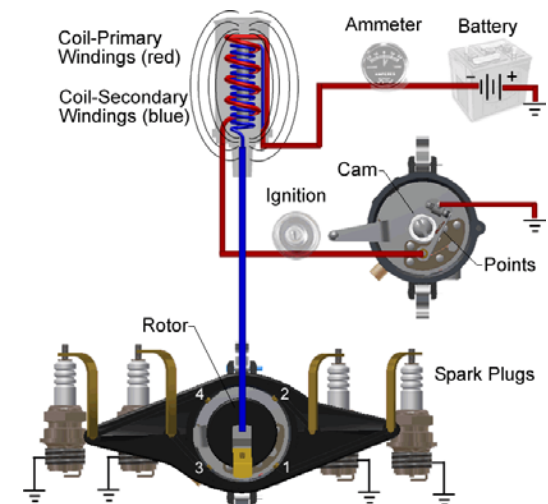



# The Ignition and Electrical Systems

## Spark Plugs

A spark plug screws into a hole in each cylinder head. The center electrode (a metal tip that is a good conductor) carries electricity, while the side electrode is connected (grounded) to the engine. At the bottom of the spark plug, the electrodes are separated by a gap only a fraction of an inch wide. Sparks must jump over this gap. Arcing can make the electrodes wear out so the gap between them widens. Waste from combustion can also build up. This is why you must replace spark plugs from time to time. Using a spark plug socket makes this task easy. Its rubber insert prevents damage to the ceramic pan of the plug.

## The Ignition Coil

Making power jump over the spark plug gap takes 40,000 or more volts of electricity, but the battery supplies only 12 volts. The *ignition coil* is the device that boosts the voltage. It has an iron core surrounded by two sets of wire *windings*. Current flows through the primary windings and generates a magnetic field around the core. When the current stops flowing, the magnetic field collapses. This makes high-voltage current flow in the secondary windings.

## Electronic Ignition

Most cars built since 1975 use some form of electric ignition to break the current flow in the ignition coil's primary windings. Solid-state electronics controlled by the engine control and turn the current off and on as needed.

## Engine Firing Order

Firing order is the sequence in which the spark plugs operate. Each cylinder has a number. On most inline engines, the cylinder in front is number 1. On V-6 and V-8 designs, one side uses even numbers (2, 4, 6, etc.) and the other side uses odd numbers (1, 3, 5, etc.). The firing order reduces unwanted vibration.

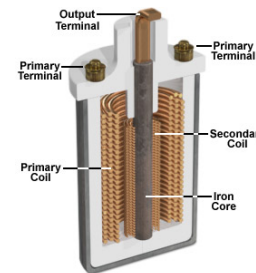

Single Coil



Coil Packs

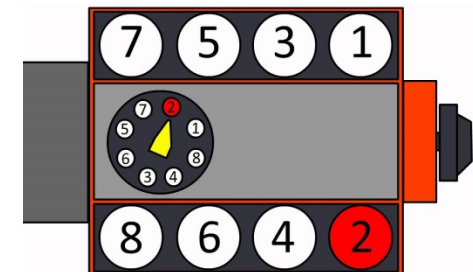

## Did You Know

Older cars used one coil and a distributor. Newer cars use coil packs at each cylinder.



# The Ignition and Electrical Systems

## Other Electrical Systems

Cars and trucks use lots of electrical devices. Many of them work only if the ignition switch is on. We will look at some of the most important electrical systems.

## The Starting System

The starter is an electric motor with gears at one end. When you turn the key in the ignition it closes a solenoid relay, a circuit that lets electricity flow to the starter and makes its gears engage (connect with) the flywheel gears. Once the engine starts, the ignition switch lets go, which opens the circuit and disengages the gears.

## The Charging System

The charging system uses an alternator to convert rotary motion (driven by belts from the engine) into electricity, which recharges the battery and drives various electrical components. A voltage regulator controls the amount of recharging.

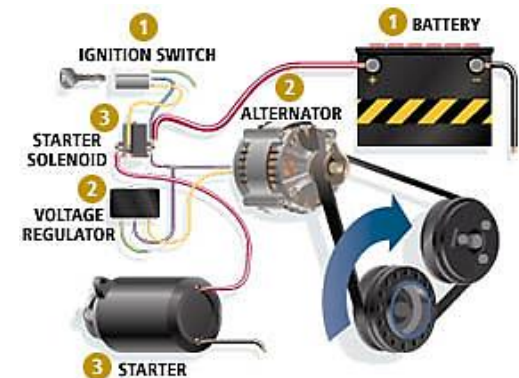

## The Lighting System

The lighting system includes the interior lights, headlights, taillights, turn signals, warning lights, hazard lights, and brake lights. When you open a car door, plunger-type switches close a circuit to the interior lights and make them go on. When you apply the brakes, a switch under the pedal closes a circuit to the brake light bulbs so they light up. You need to turn other lights on and off by hand.

## Accessories

Wires connect the battery to many other accessories, including the sound system, heating and cooling systems, and power windows and power seats. All have separate switches. In some cases (such as the sound system and the heating and cooling systems), you must also turn the ignition switch on to close the circuit to the battery.







# The Ignition and Electrical Systems

## The Battery

Like the batteries in a flashlight, a Car battery stores electricity. It has two terminals, or posts. One is marked negative(-) and the other is marked positive (+). A cable connects the negative terminal to the engine block, which acts as a ground. A second cable connects the positive terminal to the car's many electrical devices. Current flows out of the positive terminal to the electrical parts. It returns through the ground to the negative terminal. So how does a battery store electricity? Each of its six cells has a lead plate and a lead-dioxide plate, both of which are surrounded by sulfuric acid. Chemical reactions between the metal plates and the acid make about 2 volts of electricity. Because a car battery has six cells, it generates 12 volts of electricity. **Watch the Video:** [How Car Batteries Work](#)

## Battery Maintenance

Because most modern car batteries are sealed, they never need water added to them. If your battery is of the type that needs water added to its cells, check it regularly. Remove the caps on top and check the fluid level in each cell. If the fluid level is below the fill mark, add water to fill. About once a year, clean the battery terminals with a wire brush and clean the top with a [solution of water and baking soda](#). Check the cables to make sure they are tight on the terminals. Unlike flashlight batteries, lead-acid batteries can be recharged by forcing electricity back into the positive terminal. This changes electrical energy back into chemical energy.

## Using Jumper Cables to Start a Car

If you hear a clicking sound when you try to start your engine; the engine groans but does not start, the battery may be discharged. Often, you can use jumper cables and a second car battery to start the car. Here are the steps to jump-start a car.

**Caution:** Follow these instructions carefully to help avoid generating sparks; these can be a fire hazard because there are combustible gases around batteries. Wear gloves and eye protection throughout the process.

**Watch the Video:** [How to Jump Start A Car](#)



Always wear safety glasses when working around the battery. Placing a fender protector on the vehicle will protect the paint in the event of an acid spill.





# The Ignition and Electrical Systems

## Checking a Vehicle's Lights

Light bulbs in a car burn out just like the ones at home, and you must replace them. You should check all the lights on your vehicle from time to time to make sure they work properly. Turn on the headlights, which will simultaneously light the instrument lights and taillights. Check to see that each bulb is glowing. Engage the high beams on the headlights and make sure that both headlights' high beams work. Have a friend step on the brake pedal while you check to see that the brake lights work. Have him start the engine, apply the brakes, and shift into reverse while you check the backup lights. Return the car to park and turn off then engine, then turn on the hazard light switch and turn indicators. Make sure all the lights flash.



[Watch the Video](#)

## Replacing Electrical Fuses

Fuses protect vehicle electrical systems. A fuse is the weak link in an electrical circuit. When too much current is flowing, the fuse "blows," or cuts off power to protect other components from damage. The fuse panel usually is located under the instrument panel, to the left of the steering wheel, but it might be in the glove box or even in the trunk. Check the owner's manual for the location of the fuse panel on your vehicle. Labels next to fuses or on the fuse panel's cover tell you which circuit goes with each fuse. In an electrical system or accessory does not work, find the right fuse, pull it out, and see if the silvery piece of metal inside is broken and burned, which indicates that the fuse is blown. Replace the fuse with a new one of the same amperage (power) rating- typically 10, 15, 20, or 25 amps.



Good Fuse



Blown Fuse

Watch the Video: [How to Inspect and Replace Car Fuses](#)



# The Computer and Emission Control Systems

Cars today include 50 or more microprocessors-tiny computers that control everything from the fuel-air ratio to the airbags. They help reduce tailpipe emissions and make it easier for technicians to find engine problems. Before there were computers, engine systems worked mechanically using linkages, levers, springs, and vacuum devices. Even car radios had mechanical tuners. Electronic control is faster, more precise, and more reliable.

## The Electronic Control Unit

The electronic brain of the car is the engine control unit (ECU). A little smaller than a merit badge pamphlet and about 2 inches thick, the ECU typically is located beneath the instrument panel. A large connector with up to 60 circuits connects it to the car's wiring harness. The ECU receives input from dozens of sensors that monitor various engine conditions, including temperature, speed, and engine vacuum. Based on this information, the ECU decides how to adjust the engine and sends an electrical signal to an actuator, a device that converts the electrical signal into mechanical action. For example, the actuator may tell a fuel injector to spray fuel into the engine.



## On-Board Diagnostics

The on-board diagnostics (OBD) system helps technicians find problems with the engine and other systems. When the ECU data indicates a problem with the engine, it generates a fault code, which is like an abbreviated error message. A technician can look at this code to help pinpoint what is wrong. Since the 1996 model year, manufacturers have used a set of fault codes called the OBD-II specification. A typical OBD-II fault code would be P0171.

Here's what that code tells the technician:

- P stands for powertrain.
- 0 means it is a generic code. (This digit is always either 0 or 1; 1 means the fault code is specific to the manufacturer.)
- 1 means it is related to the emission management system.
- 71 tells you the problem. In this case, the system is running too lean on bank 1 (the side of the engine with cylinder No. 1).



OBD-II Scan Tool



# The Computer and Emission Control Systems

## Emission Control Systems

Almost every engine system has something to do with emission control. However, most car-related pollution comes from three sources: exhaust gases, evaporation, and crankcase gases.

### Exhaust Gases

Exhaust gases are the result of fuel combustion and are exited through the tailpipe. The catalytic converter controls these gases, using chemical elements like platinum, palladium, and rhodium to turn nitrogen oxides, carbon monoxide, and hydrocarbons into less harmful emissions like oxygen, carbon dioxide, and water.

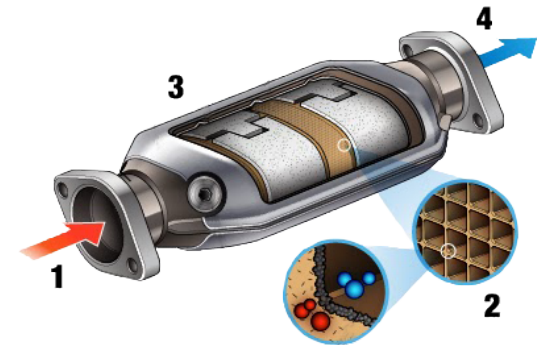

### Evaporative Emissions

Evaporative emissions occur when gasoline vapors evaporate (escape into the air in the form of a gas). To control these emissions, Fuel-tank vapors pass through canisters of activated carbon before going into the engine to burn. A spring-loaded door on your car's fuel-tank filler neck keeps evaporative emissions from escaping when the tank is open at the gas station. Since the 2000 model year, all cars sold in the United States have had an onboard refueling vapor recovery system, which captures vapors from the fuel tank during refueling.

### Crankcase Gases

crankcase gases, also known as blow-by gases, are gases that pass between the piston and cylinder wall and collect in the bottom of the engine. The positive crankcase ventilation (PCV) valve re-cycles these gases into the air cleaner or the intake manifold, where they can join the air-fuel mixture and re-burn.

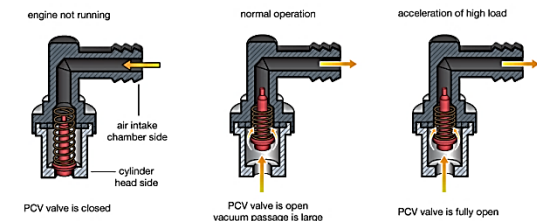



# Complete Requirement # 8

## Ignition and Electrical Systems

Do the following:

- a. In your workbook or on a piece of paper diagram and explain the parts of the electrical system.
- b. In your workbook or on a piece of paper explain the cylinder engine sequence.
- c. In your workbook or on a piece of paper explain the purpose of the spark gap.

**Once completed arrange a meeting with your counselor**

- d. Demonstrate how to safely connect jumper cables to your car battery.

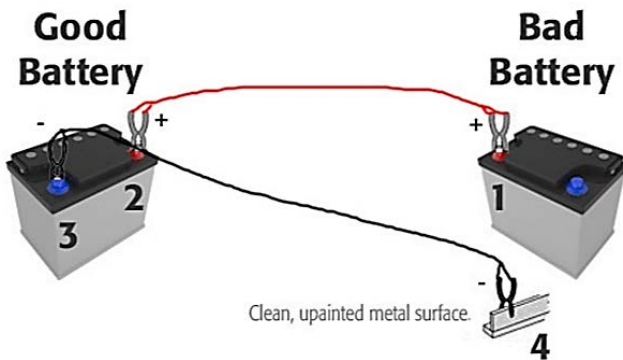





# The Drive Train

The drive train is the set of parts, starting with the transmission, that send power from the engine to the wheels. Most cars today use front-wheel drive (FWD), so the drive train connects just to the front wheels. Other vehicles use rear-wheel drive (RWD). Many trucks and SUVs feature all-wheel drive (AWD) or four wheel drive (4WD) which means the transmission powers all four wheels.

## The Transmission

Every engine produces the most horsepower and torque (twisting power) at or near a certain speed- say, 5,000 rpm. However, the wheels do not always need the same amount of power, so the transmission multiplies torque by sending power between different-sized gears. When a smaller gear turns a larger gear, the bigger gear rotates more slowly and sends more power to the wheels. For example if a 3 inch gear turns a 6 inch gear (a 2:1 gear ratio), the smaller gear turns twice as fast, but the larger gear creates twice the torque.

You may have seen this idea at work on a bicycle. If your chain is on a small chain ring in the front and a large sprocket in the back, it will help you climb a very steep hill. If it is on a large chainring and a small sprocket it will help you pedal along a flat road at high speed. A key difference between a car transmission and a bicycle gear set is that on a bicycle, you can use any chain ring with any sprocket. On a car, however, the gears on the input shaft (coming from the engine) and the output shaft (going toward the wheels) are always connected in pairs. Each time you shift gears, the transmission tells a different pair of gears to send power to the wheels. There are two basic types of transmissions: manual and automatic.

Manual Transmission

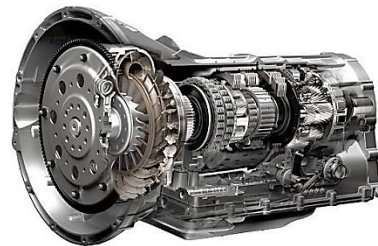

Automatic Transmission

Semi-automatic Transmission

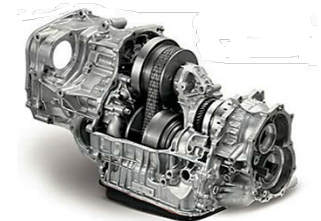
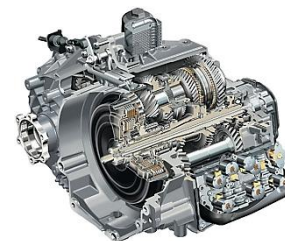

Continuously Variable Transmission



# The Drive Train

## Manual Transmissions

Just before shifting gears, the driver must push a pedal down to release the clutch. This temporarily disconnects the wheels from the engine so the driver can select a gear by using a shift lever. The clutch has a round disc about the size of a dinner plate, that is covered with friction material. When the clutch pedal is out, this disc rests tightly against the engine flywheel. This makes the transmission's input shaft spin at the same speed as the crankshaft.

Watch the video: [Manual Transmission](#)



## Automatic Transmissions

An automatic transmission shifts itself. There is no clutch pedal; the driver just has to move the shift lever to D (drive) to use the car's forward gears. *hydraulic* (Fluid) pressure flowing through various pathways does all the work. An automatic transmission senses engine speed and vehicle speed and then picks the appropriate gear ratio.

Watch the video: [Automatic Transmissic](#)



## Continuously Variable Transmission (CVT)

**CVT** is an automatic transmission that can change seamlessly through a continuous range of effective gear ratios. The flexibility of a CVT allows the input shaft to maintain a constant velocity. The belt-driven design offers approximately 88% efficiency, which, while lower than that of a manual transmission, can be offset by lower production cost and by enabling the engine to run at its most efficient speed for a range of output speeds.

Watch the video: [Continuously Variable Transmission](#)





# The Drive Train

## Other Drive Train Components

The makeup of the drive train varies depending on whether a vehicle is FWD, RWD, or 4WD / AWD. In FWD vehicles, the engine is mounted transversal; the driveshaft goes from side to side, not front to back. A combination transmission and axle called a transaxle-sends power directly to axle shafts, which turn the front wheels. In RWD vehicles, the engine, Transmission, driveshaft, and axle differential connect in a straight line like cars on a train. Power from the engine makes a right turn at the rear axle differential, then the axle shafts send power to the rear wheels. The drive trains on 4WD and AWD vehicles are set up like those on RWD vehicles. The transfer case on the transmission distributes power to the front wheels through a second drive shaft and front axle assembly.

Watch the video: [Rear-Wheel Drive vs Front-Wheel Drive vs All-Wheel Drive](#)

## The Differential

The differential is inside the rear axle housing (on RWD vehicles) or the transaxle (on FWD vehicles). It has a special set of gears, called a ring and pinion. The driveshaft turns the smaller pinion gear, which sends power at a 90-degree angle to the ring gear. As in the transmission, twisting power increases as the smaller pinion turns the larger ring gear. Most axle gear ratios are around 2.75:1, which gives good overall performance. A lower ratio, such as 2.10:1, offers more fuel economy but slower acceleration. A higher ratio, such as 3.98:1, creates more power and acceleration.

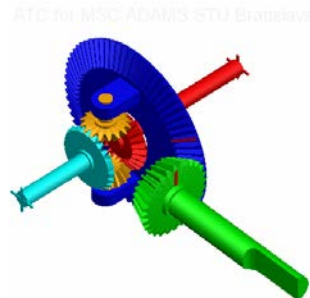

Watch the video: [Differential](#)



# The Drive Train

## Checking Transmission Fluids

**Manual transmissions** and rear axles use gear lubricant, which is a little heavier than motor oil. This fluid does not need to be changed unless there is a problem. You can check the level by unscrewing the metal filler plug while the vehicle is on a hoist.

**Automatic transmissions** use a lightweight fluid that not only lubricates but also works the hydraulic circuits. Different manufacturers call for slightly different types of fluid. You can check the transmission fluid level with a dipstick, which is usually at the rear of the engine compartment. Make sure the shift lever is in park and set the parking brake. With the engine idling, pull out the dipstick, wipe it off with a clean, lint-free cloth, put it in again, and pull it out again. If the fluid level is at or below the "Add" mark, top it off.

The transaxle on FWD cars with manual transmissions uses a single fluid (similar to RWD cars). Cars with automatic transmissions use one fluid for the differential and another fluid for the transmission part of the transaxle.

## Checking Power Steering Fluid

The power steering system uses hydraulic pressure to make it easy to turn the steering wheel. Power steering fluid should be checked often and replaced according to the specifications in the owner's manual. To check the fluid level, take the cap off the top of the power steering pump, which usually can be found at the front of the engine on the driver's side. If fluid is needed, add it to the reservoir. Some cars have a clear plastic reservoir that lets you check the level without taking the cap off. Rock the car gently to see the fluid level.

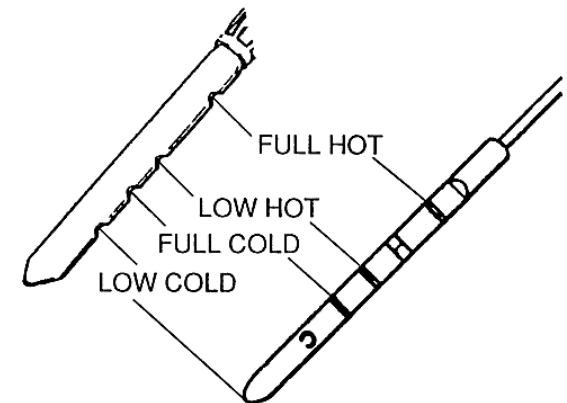



# Complete Requirement # 9

## Drive Train

Do the following:

- a. In your workbook or on a piece of paper diagram the drive train and explain the different parts.
- b. In your workbook or on a piece of paper explain the difference between automatic and standard transmissions.
- c. In your workbook explain the types of automatic transmission fluid.
- d. In your workbook or on a piece of paper explain the types of lubricants used in a standard transmission and in the differential.
- e. In your workbook or on a piece of paper explain the difference between front-wheel, rear-wheel, and four-wheel drive.

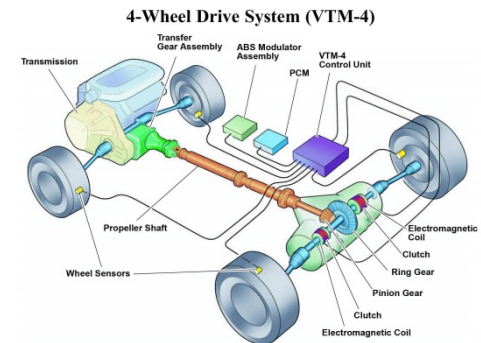
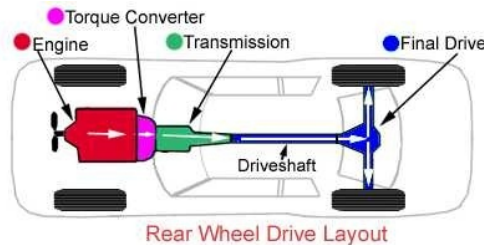
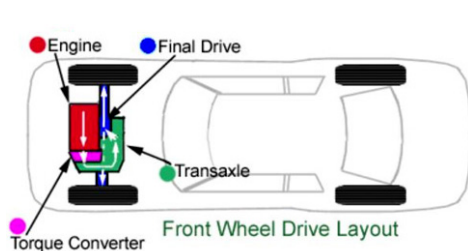

PROCEED TO "The Braking System"





# The Braking System

The braking system allows the driver to control the speed of the vehicle by applying frictional force (resistance) to the rotating wheels. This slows or stops the vehicle.

## How the Braking System Works

Two things happen when the driver's foot pushes the brake pedal down. First, a hydraulic (fluid-filled) circuit multiplies this pedal pressure and sends it to all four wheels. Second, the hydraulic pressure at each wheel pushes against brake pads or linings, which have a special cloth called frictional material attached. These pads or linings rub against a rotating cylinder called a drum or rotor that is attached to the wheel. Friction makes the wheel slow down.

## What Is Friction?

Friction is resistance to motion. If you run on a gym floor in hard-soled shoes, you will slide when you try to stop or change direction quickly. If you are wearing sneakers, it is much easier to stop and turn. That is because rubber has higher friction than other materials. Automotive brakes need to be made of much tougher materials than shoes. They are made of special compounds that lose heat quickly and wear very slowly.

## Hydraulic Circuit

The brake pedal is attached to a master cylinder; which holds two containers (reservoirs) of brake fluid and two plungers. When you apply the brake pedal, the plungers force fluid through steel tubing to the wheels. The fluid presses against wheel cylinders, which in turn move the brake pads or linings to create friction. This changes motion energy into heat energy that goes out easily into the air. The brake system needs hydraulic pressure to build up when the driver presses the brake pedal. If there is a leak in the system, pressure cannot build up and the brakes will not work. To prevent dangerous brake failure, modern cars have two separate brake circuits. (That is why the master cylinder has two fluid reservoirs and two plungers.) If one circuit has a leak, there will still be braking power in the other. Typically, the circuits are cross-linked, which means that one circuit powers the left-front and right-rear brakes, while the other powers the right-front and left-rear brakes.

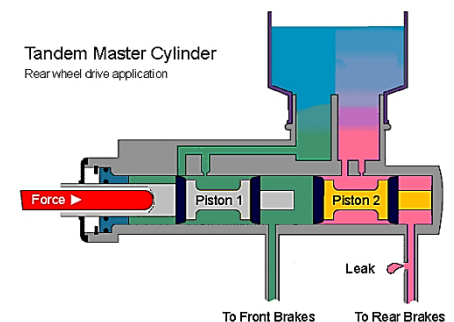



# The Braking System

## Types of Braking Systems

There are two major types of brakes: drum brakes and disc brakes. Drum brakes force curved pads, called brake shoes, to rub against the inside of an iron drum. Disc brakes use pairs of levers, called calipers, that clamp small brake pads against the sides of a spinning iron disc and a rotor. (This is how bicycle brakes work, too.) Disc brakes are better for severe operating conditions, because air cools the rotor, helping heat go away more quickly. New cars usually have drum brakes in the rear and disc brakes in the front. High-performance models have disc brakes at all four wheels.

## Antilock Brakes

To stop or slow a moving vehicle, you need two kinds of friction: friction between the brakes and the wheels and friction between the wheels and the road. If the driver hits the brakes too hard and the wheels lock up (stop turning), the car can skid out of control. An antilock braking system (ABS) keeps the wheels from locking up by adjusting the amount of pressure they apply to each brake. When sensors feel that a wheel is about to stop turning, the ABS computer tells the brake system's hydraulic control unit to use less braking force to the wheel or wheels that are about to lock. This balances the braking at all four wheels and gives the driver better control of the vehicle. In order for ABS brakes to work properly, the driver should apply steady pressure to the brake pedal rather than pumping it. If the driver can hear mechanical noise or notice "pulsing" during a hard brake, the ABS system is working.

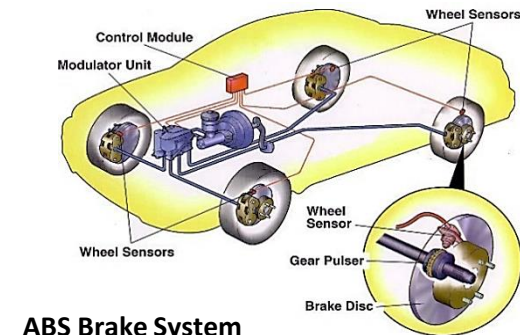
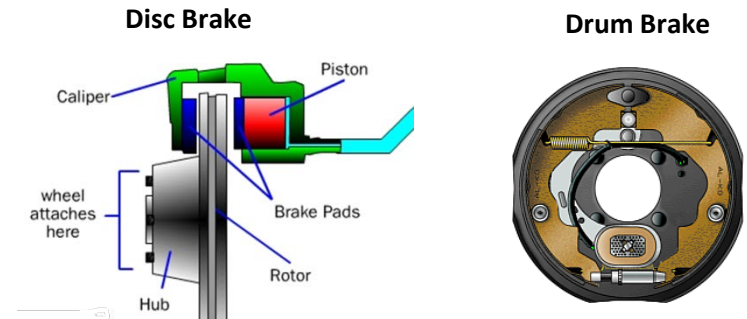

ABS Brake System



# The Braking System

## Brake Maintenance

Brake fluid levels can go down over time. They can go down quite fast if there is a leak in the system. Brake pads and linings must be replaced periodically. How quickly they wear out depends on the driver's habits, such as how hard and how often he brakes and whether he drives in a lot of stop-and-go traffic.

## Checking the Brake Fluid

To check the brake fluid, take the cap off the top of the master cylinder. It is on the driver's side of the engine compartment near the firewall (protective barrier that separates the passenger from the engine). If necessary, top off the fluid with fresh brake fluid. Use the kind called for in the owner's manual (probably DOT 3). Some cars use a clear plastic top that lets you check the fluid level without taking off the cap. Rocking the car gently helps you easily see the fluid level.

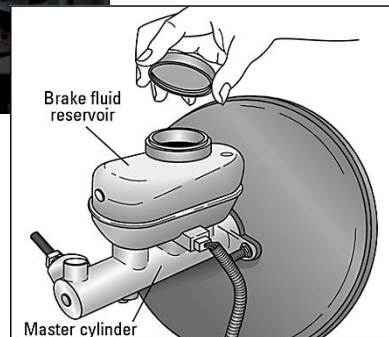



# The Braking System

## Inspecting the Brakes

Most manufacturers recommend that you check the brakes after the first 6,000 miles, then at every scheduled service interval.

You should check the brakes as soon as possible if you notice any of these problems:

- The brake indicator or ABS indicator on the dashboard lights up.
- The brake pedal goes almost to the floor before you feel the brakes go on. This could indicate low brake fluid level or fluid leak.
- You hear a squealing sound. This could mean that the brake pads are wearing thin.
- You feel vibration or shaking or hear the sound of metal on metal; this could mean that the rotors are damaged.

To check your brakes, first jack up the car and take off the wheel and tire assembly. Remove the drum, if there is one. Check the pads or linings for wear. Replace them if the frictional material is worn to within about 0.030 inch ( $\frac{1}{32}$  inch) of the metal shoe. Inspect the rotors and look inside the drums for damage or overheating. These problems will cause a bluish color. Light scratch marks are acceptable, but if the marks are more than 0.015 inch ( $\frac{1}{64}$  inch) deep, you need to replace the rotor or drum or take it to a shop that can machine it to make the surface smooth again.

Watch the video: [Brake Pad Inspection](#)

Watch the video: [How to Know When Car Brakes Need Replacing](#)





# Complete Requirement # 10



## The Braking System

Do the following:

- In your workbook or on a piece of paper explain the [brake system](#) (including anti-lock systems) and how it operates.
- In your workbook or on a piece of paper explain the differences between disc and drum systems.

**Once a and b have been completed arrange a meeting with your counselor**

- With your counselor** demonstrate how to check the condition of a vehicle's brake system. After checking make recommendations for repairs (if necessary).







# Buying a Car

Owning a car is a big part of the American dream. A car is also the first major purchase that many people make. To get the best car for the best price, you have to do your homework. The internet and printed pricing guides can help.

## **Finding and Buying a Car**

Before you start actually looking at cars, think about what kind of car you would like to buy. Should it be a four-door or two door sedan, a hatchback or minivan, a truck, or an SUV? Which features do you think are important? Which ones are less important to you? Keep in mind that you will also need enough money to pay for taxes, registration, insurance, gasoline, and maintenance.

Next, look at cars at local dealerships or from private sellers that fit your needs. Take cars you like for a test drive. With your parent's permission, visit Web sites like [cars.com](http://cars.com) to read detailed reviews of the models you are considering.

Once you have found a car you really like, have a mechanic inspect it before you buy it. Many shops offer free courtesy checks. You can also use the vehicle identification number (VIN) to look up the individual vehicle's history at Web sites like [carfax.com](http://carfax.com). If you find out that the car has been in a serious accident, keep shopping. You should also avoid a car whose title (the document that shows ownership) has been rebuilt; cars with rebuilt titles have typically been sold as salvage vehicles and then repaired.

Finally, bargain on a price of the car that is fair to both you and the seller. Unlike prices on most other products, car prices usually negotiated. Printed price guides like the [Kelley Blue Book](#), and the Web sites that go with them, suggest prices for thousands of used cars based on condition, options, mileage, and other factors. Usually these prices range from the trade-in price (what a car dealer would give you as a trade-in credit) to the retail price (what a car dealer would charge for the car). You should aim to pay a price in the middle.

**Watch the video: [How to Buy a Car](#)**



# Buying a Car

## New or Used?

When deciding whether to buy a new car or a used car, you have several factors to weigh. Rely on your common sense, and stick to your budget and what you need from your car. New cars offer peace of mind in that they should not require as much maintenance as soon as a used car would, and a new car most likely would be covered under a manufacturer's warranty for a few years. While they might not appear as appealing as a new car, used cars can be just as reliable and a great deal less costly. Many used-car programs today offer vehicles that have been through an intensive inspection process and are guaranteed to be in good shape. And depending on the age of the car, it might still be covered under the manufacturer's warranty. Ultimately, the choice is up to you.

The screenshot shows the cars.com website interface. At the top, there's a navigation bar with links for 'Buy', 'Sell & Trade', 'Service & Repair', and 'News'. A large banner features a blue car with the text 'It's easy. Let's go.' Below the banner, there are search filters for 'New', 'Used', 'Certified Pre-Owned', and 'All'. A search bar shows 'Toyota' and 'Tundra'. There are also links for 'Search Cars for Sale', 'Read Specs & Reviews', and 'Find Service Centers & Dealers'. A 'Kelley Blue Book' logo is visible, along with a 'First Pics: See the New Cars of 2017' section.

The screenshot shows the ConsumerReports website. The main heading is 'Choose a car that's perfect for you' with the subtext 'Know before you buy. Make an informed choice.' Below this, there's a section titled 'Get unbiased ratings and recommendations' with a right-pointing arrow. The text says 'Our experts thoroughly tested a wide range of cars at our Auto Test Center so you can choose the car that's right for you.' A list of car classes is shown with checkboxes: Convertibles, Hybrid/EVs, Luxury cars, Minivans, Pickup trucks, Sedans, Small cars, Sports cars, SUVs, and Wagons. A blue sports car is visible in the background.

The screenshot shows the CARFAX website. The main heading is 'Shopping for a Used Car?' with the subtext 'Start your search with CARFAX Used Car Listings. Every car comes with a FREE CARFAX Report!'. There are two buttons: 'Find a Used Car' and 'Get CARFAX Reports'. A cartoon fox character wearing a 'CAR FOX' shirt is visible in the foreground.



# Buying a Car

## Buying Insurance

The law says you must have liability insurance before operating a motor vehicle. Other types of insurance are not required by law but are a good idea to have. Here are some common kinds of insurance coverage.

- Liability. Pays the other person when you hurt them or damage their property
- Collision. Pays for repairs to your vehicle when you cause an accident
- Comprehensive. Pays for damage to your vehicle that was not caused by an accident, like damage by vandalism or fire
- Medical. Pays medical expenses for you and your passengers after an accident
- Uninsured/underinsured motorist. Protects you if you are hit by someone who does not have auto insurance or does not have enough to pay for the damage caused
- Towing. Pays for towing if your car breaks down
- Rental car. Pays for a rental car for you to drive while your car is being repaired after an accident

The cost of insurance will vary depending on many factors, including your age, where you live, your driving record, and the type of car you are insuring. The Insurance Institute for Highway Safety estimates that insurance makes up 11 percent of the cost of owning a car over five years, so be sure to first check with your insurer on the costs of insuring the make and model of the car before you buy.

**Watch the Video: [Understanding 5 Types of Car Insurance Coverage](#)**



# Complete Requirement # 11

Do **TWO** of the following:

- Determine the value of three different vehicles you are interested in purchasing. One must be new and one must be used; the third vehicle can be new or used. For each vehicle, find out the requirements and cost of automobile insurance to include basic liability and options for collision, comprehensive, towing, and rental car. Using the three vehicles you chose and with your merit badge counselor's assistance, complete the operation/maintenance chart provided in the merit badge pamphlet. Use this information to determine the operating cost per mile for each vehicle, and discuss what you learn with your counselor.
- Choose a car cleaner and wax product for a vehicle you want to clean. Explain [clear-coat paint](#) and the precautions necessary for care. Clean the vehicle, both inside and out, and wax the exterior. Use a vinyl and rubber protectant (on vinyl tops, rubber door seals, sidewalls, etc.) and explain the importance of the protectant.
- Locate the manufacturer's jack. Use the jack to demonstrate how to [engage the jack](#) correctly on the vehicle, then change a tire correctly.
- Perform an oil filter and oil change on a vehicle. Explain how to properly dispose of the used oil and filter.



Once completed arrange a meeting with your counselor



# Careers in Automotive Maintenance

The automobile was once a simple piece of machinery. Today, it is a sophisticated mode of transportation. This change shows in whom we call people who take care of cars. Fifty years ago. They were called mechanics, today we call them technicians. To work on today's vehicles, knowing how to use wrenches and hand tools is not near enough. Technicians also need to know how to work with technologies like the engine control unit and on board diagnostics.

## Position Descriptions

Automotive service has two major divisions: mechanical repairs, which includes diagnosing and fixing vehicle systems, and body repairs, which includes repairing and painting sheet metal and other body materials.

## Mechanical Repair Positions

There are four main kinds of mechanical repair positions.

- Apprentice is an entry-level position. Apprentices perform minor repairs and help experienced technicians.
- General technician is the most common position. These technicians can perform almost any automotive service task.
- Specialty technicians spend most of their time working in one area, such as air conditioning or automatic transmissions. They usually need extra training and experience.
- Diagnostic technicians have advanced training on how to work with computer systems and electronic components. They find the cause of problems. They often work on "problem vehicles" that other technicians cannot repair.



# Careers in Automotive Maintenance

## Body Repair Positions

Body shops fix exterior damage to vehicles. There are three basic positions. Duties may overlap, especially in a small shop.

- Estimators inspect a vehicle to determine the time, materials required, and cost to make a repair. The estimate forms the basis of the price the shop quotes to the Customer.
- Body repairers use hammers, bending tools, and many other tools to put damaged fenders, doors, and body panels back to like-new condition.
- Painters mix paint to match a vehicle's current color, apply it, and refinish the surface to remove all signs of the repair.

## Other Automotive Maintenance Positions

Large service organizations like dealerships employ a variety of other people. They include service advisers, who greet customers and prepare repair orders; service managers, who run the service department; parts managers, who are in charge of selling replacement parts; and parts counter workers who sell parts to customers and fill requests from the service department. Automotive service is exciting, challenging and important work. No two days, and no two vehicles, are just the same. As cars become even more complex, the opportunities will keep growing for people who want to put their hands- and their brains- to work under the hood.

## Technician Certification

Service organizations want to make sure they have the best possible technicians working in their garages. Car manufacturers offer training programs for technicians who fix the cars they make. In addition, many technicians receive certification from the National Institute for Automotive Service Excellence. This group offers certification in specific areas (brakes, engine repair, etc.) that is good for five years. ASE certification can make the difference when a would-be technician is applying for a position.





# Complete Requirement # 12

Find out about three career opportunities in the automotive industry. Pick one and find out about the education, training, and experience required for this profession.

Discuss this with your counselor, and explain why this profession might interest you.



Once completed arrange a meeting with your counselor



# **Congratulations Scout!**

**You have just earned your  
Automotive Maintenance  
Merit Badge**

