

Event Guide

(revision January 3, 2021)

Chippewa District Activities Committee

Presents

KLONDIKE DERBY 2021

Saturday February 6, 2021

Cantigny Park

1S151 Winfield Rd.

Wheaton, IL 60189

Register On-Line at

www.ChippewaDistrict.org

Event Check-in 8:30 am

Competition 9:00 am – 3:00 pm



WHAT IS THE KLONDIKE DERBY

The Klondike Derby is a day-long annual event hosted by The Chippewa District Activities Committee for Scouts BSA units and Webelos/Arrow of Light Cub Scouts. Scouts compete as patrols in several outdoor skill events. A score is given at each station. Scores are tallied at the end of the day and ribbons are awarded to the top scoring patrols. Cub Scouts and Scouts BSA units receive separate awards.

Scouts compete as a patrol of 6 – 8 youth. Each patrol brings a “Klondike sledge” which is styled after the type of sledge (sled) used by gold miners in the Klondike Gold Rush from 1896 – 1899. Each sledge must carry specific equipment needed to complete the competition. Sledge designs and the equipment list are described later in this guide.

Local Troops run the competition stations, which are given names themed around the Klondike Gold Rush. The station activities are designed to last about 30 minutes each and will accommodate approximately 3 patrols at a time. Stations this year are:

First Aid	Bear Bag Toss
Team Building	Log Sawing
Sled Race	Signaling
Tomahawk Throw	Knot Tying
Lashings	Fire Building

There will not be any camping at the 2021 event due to the pandemic.

2021 PANDEMIC RESTRICTIONS

The State of Illinois has imposed special restrictions due to the global COVID-19 pandemic. This event will be held only if State of Illinois regulations allow for group gatherings of 50 persons. The 50-person limit will be strictly enforced. Patrols will be assigned into 5 cohorts that combine competitors and event operators to keep total group size less than 50 persons. Participation will be capped at 30 patrols total. Patrols will move on a fixed timetable to the next cohort so that the capacity limit is maintained. Competitors must wear a facemask at all times and make a strong effort maintain social distance at all times. Gloves should be worn and sanitation effort made to minimize touch contact.

If State of Illinois regulations do not permit the event to be held as planned, it will be postponed to a future date. We intend to eventually hold the event in 2021, even if it is summer!

KEY CONTACTS

Sean Nadeau, District Executive, 630-797-4630
sean.nadeau@scouting.org

Rich Tatara, Event Chair 630-280-4905,
rmtatara428@gmail.com

KLONDIKE DERBY LOCATION

Cantigny Park
1S151 Winfield Rd.
Wheaton, IL 60189

Enter via the main gate and identify yourself to the security guard as a participant in the Scouts BSA event. Scouts and leaders will be able to enter the park without charge. Proceed forward to the main visitor center parking lot.

Due to the pandemic social distancing rules, the Visitor Center will be open to participants only for access to the restrooms. Only Patrol leaders or designated adult leaders will be able to enter the Visitor Center for registration purposes.

Please be prepared to be outside all day.

KLONDIKE TIMETABLE

January 9	On-Line Registration Opens
January 23	Late On-line Registration Begins
February 1	Event Go/No-Go Decision Date
February 3	Registration Ends

February 6th Saturday

8:30 A.M.	Check in opens – Visitor Center Patrols proceed to assigned Cohort starting point
9:00 A.M.	Events begin
10:00 A.M.	Passing Period
10:10 A.M.	Events Continue
11:10 A.M.	Passing Period
11:20 A.M.	Events Continue
12:20 P.M.	Lunch – Brought by Patrols
12:40 P.M.	Passing Period
12:50 P.M.	Events Continue
1:50 P.M.	Passing Period
2:00 P.M.	Events Continue - Final Round
3:00 P.M.	Scoresheet Turn-in & Patrols Disperse (go home)
TBD	Results will be announced via TFC and Chippewa District Websites.

REGISTRATION

Units may only participate in the event by registering on-line. There will not be any day-of-event entries due to the requirement to meet State of Illinois pandemic guidelines. The main registration site is found at www.ThreeFiresCouncil.org, then select the calendar. Make sure you select the Chippewa District calendar filter. As an alternative, you can navigate to registration via www.chippewadistrict.org/

Leaders will register for the event as a patrol. The total number of patrols is limited due to pandemic regulations. Each troop or pack will be allowed to register one patrol. Only units from Three Fires Council Chippewa District will be allowed to register.

A patrol can consist of up to 6 Scouts BSA youth/adults or up to 8 Webelos scouts/adults. Unregistered personnel will not be allowed to accompany the patrols due to the need to manage the 50-person cohort limit.

The initial registration will simply reserve a patrol for your unit in the competition. Once reserved, you will be able to add the names of the final participants at any time before the February 3 deadline.

Units that do not have enough competitors to fill a patrol are encouraged to contact neighboring troops/packs to identify additional participants to fill a patrol. In this case, only one unit should register a patrol, then supply names for all the scouts participating.

There is a separate registration for leaders/scouts who will be operating events. There should be no more than 6 persons per event.

COST

This event is included in the Three Fires Council 2021 Activity Fee. There is no charge for units that register a patrol during the initial on-line registration period (1/9 – 1/22).

Per Three Fires Council Activity Fee guidelines, units who register a patrol during the late registration period will incur a charge of \$10 per participant (i.e., \$60 for a 6-person patrol).

As previously stated, units who register a patrol during the regular registration period will be able to supply the names of the competitors at any time up to February 3 without penalty.

Admission includes:
Cantigny Park grounds access
Competition entry
Event patch
Hot chocolate & lemon drink throughout the day

EVENT CHECK-IN

Patrols will check-in at the Cantigny Visitors Center before 9:00 am on the day of the event. Only one patrol leader will be allowed into the building for this purpose. The patrol leader will be required to show the following 2 documents:

- a completed roster form listing all scouts and adults attending (blank form found at the end of this guide)
- Part A & B medical forms for their participants (see below)

MEDICAL FORMS AND TOUR PERMIT

All patrols should bring Part A & B medical forms for their participants. Leaders will produce the forms at check-in, but then retain them throughout the event. Units will not need a separate tour permit for this event. Medical forms can be found here:

https://filestore.scouting.org/filestore/HealthSafety/pdf/680-001_AB.pdf

LUNCH PLANNING

Due to pandemic restrictions, there will not be lunch provided in closed quarters this year. All participants should plan to bring their own lunch which will be consumed outside during the designated lunch period. Hot chocolate and lemonade will be made available throughout the day. Each participant should bring their own insulated drink container.

SLEDGE/SLED REQUIREMENT

Patrols competing in the event must transport their gear on a homemade sledge pulled by the scouts. Most troops/packs already have a sledge that has been passed down from generation to generation. If you need to construct a sledge, plans are included at the end of this guide and may be easily found on-line. If you need to borrow a sledge, this can be arranged, but we need at least two weeks notice to contact nearby packs and troops who may be able to loan a sledge for this event. If there is little or no snow present for the event, then you must construct an alternate means to move your sledge through the event; some sledge designs have optional wheels built into their sledge, while others could place their sledge on trolleys or wagons. In a pinch, units can use toboggans, plastic sleds or wagons to carry their gear through the competition, but it may be harder to earn Klondike Spirit points during the competition.



GEAR FOR THE SLEDGE

IMPORTANT!!! There are several things you **MUST** bring for your sledge, and each competing patrol will be judged on their **readiness**. Most units place these items in plastic bins on the Sledge. They will be transported on the sledge by the patrol throughout the day.

Here is the list:

- **Class A & B Medical Form for each patrol member**
- **Enough DRY firewood, tinder, and kindling to build a small campfire.**
- **A Patrol Flag and Cheer**
- **6 ft. rope per scout**
- **One 25 ft. rope per sled**
- **Blanket and/or tarp**
- **3 – 6 Lashing staves/poles**
- **Compass**
- **Matches**
- **First Aid Kit**
- **Clip Board**
- **Pencil and Paper**
- **Water bottle for each Scout**
- **Hot beverage container for each scout**
- **Scout handbook with knot illustrations/instructions**

INSTRUCTIONS FOR TROOPS RUNNING A STATION

- Your unit should arrive early to be prepared for the competition start sharply at 9:00 am on Saturday morning and run continuously through 3:30 pm (including coverage during lunch period).
- Your event should be operated by no more than 6 scouts + adult leaders total. This rule is in place to help manage the 50-person limit per cohort. Scouts who operate an event will not have an opportunity to compete unless they trade-places with scouts in a patrol.
- Your event needs to be scaled so that at least 3 patrols can complete your event within 30 minutes. This will enable all 6 patrols in a cohort to complete both events in a cohort within a one-hour period.
- Your event must include a method of scoring that accounts for demonstrated skill level, especially as it relates to excellence in traditional scout skills. It should also account for the difference in skill level between Scouts BSA and Webelos Scouts. Your scoring should include extra points for spirit and enthusiasm.

WINTER EVENT CLOTHING

The Klondike Derby is an outdoor wintertime event, so **participants must dress appropriately to be outside all day**. There are many variables affecting the choice of strategy for staying comfortable in cold weather: weather conditions, ground cover conditions, activity level, variability of activity level, etc. It is expected that all participants will be suitably dressed for winter conditions, including long underwear, water repellant pants, warm coat, gloves and hat. In addition, here a few things to do differently for a Klondike Derby:

- Remember, the insulator in all clothing is air. Loose, thick and dry clothes provide more insulation. Thin or tightly drawn clothes provide little insulation. Most mistakes involve forgetting this. Protection from wind by an outer “shell” is also a key item.
- Add insulation to your legs and head. Most people wear less insulation on their legs and head because they don't feel cold, but these body parts dump out a huge amount of body heat.
- You need especially thick, loose insulation on your feet. Your summer shoes/boots don't have room for this. So, use insulated boots, or else shoes/boots that are 2 or 3 sizes bigger than your summer shoes, and put 2-3 pairs of non-cotton socks on.
- If your fingers get cold, make sure your gloves are thick and loose. Better yet, wear mittens instead of gloves.
- Get moving! Even a small amount of activity will make a big difference.

Cold Weather Clothing & Sleeping Gear Videos

There are many variables affecting the choice of strategy for staying comfortable in cold weather. A few years ago we made two videos that cover these topics specifically for Klondike. They are on YouTube:

Clothing video title: Clothing2.flv

Clothing video link:

<https://www.youtube.com/watch?v=N2QYjvoburl>

Sleeping gear video title: SleepingBag.flv

Sleeping gear link:

<https://www.youtube.com/watch?v=QrvbBwlepFw>

2021 Chippewa Klondike Competition Events

1. **Bear Bag** – each member of the patrol will tie a bear bag knot. The final bear bag will be hoisted up a bear bag pole/tree and properly secured to a tree. Patrol should have a rope and bear bag on their sled, but the station should have an extra rope and bear bag.
2. **First Aid** - the patrol comes around the bend of the trail and finds an injured scout. Properly administer first aid for this scout. Materials: Patrol should have first aid materials on their sled. The station could supply an injured scout or ask one of the contestants to be the injured scout.
3. **Camp Gadgets/lashings** the patrol will work together to lash a tripod with leg braces to support a 2.5 gallon water jug or construct some other camp gadget as devised by the station. Patrol should bring lashing ropes or twine and 6 poles. Station should have extra ropes and poles.
4. **Fire Building** – Patrol will build a fire; boil some water to warm them up. Patrol will bring matches, pot, water, cups, spoon and hot cocoa mix. Station should have extra pots and provide tinder, kindling and fuel.
5. **Log Town (log sawing)** – Station will provide the Scouts two-man saws and improvised sawbucks. They must saw through a six-inch log against the clock. They can keep the chunk they saw off.
6. **Tomahawk throw/Wrist Rockets** – Station will provide hand axes and stumps for throwing competition (Scouts BSA) and set up a wrist rocket station (Webelos) using dog food. Requires trained range officer.
7. **Sled Race** – The ultimate Klondike Derby event. Station will section off a course of about 500 feet, then time the patrols as they compete for the title of fastest sled using stopwatch or app on phone.
8. **Teambuilding** – Station to run a teambuilding activity, such as Isotope Relay, Survival Rope Throw (Tie and throw rescue rope to "victim" on cardboard ice floe or simulated ice break-through), Group Ski Race (using 4-man skis), etc.
9. **Signaling** - Patrols have five minutes to decide on a method of signaling a silent message to a line-of-sight outpost. Station gives two Scouts a short message and send them to a visible point—for example, a point 75 yards down the trail— and instruct the scouts to signal the message back to their mates.
10. **Knot Tying**- Patrols must complete specified knots while being timed.

Note: Final definition of each event is subject to variation depending upon decision of the event operator.

CHIPPEWA DISTRICT KLONDIKE DERBY 2021
Roster Form to be turned in at Klondike Registration

UNIT NUMBER	TOWN
PATROL NAME	
PATROL LEADER	
YOUTH NAME	
1	
2	
3	
4	
5	
6	
7	
8	
ADULT LEADER NAME	
1	
2	
3	
4	
TOTAL NUMBER OF YOUTH: _____	
TOTAL NUMBER OF ADULTS: _____	
TOTAL NUMBER IN ATTENDANCE: _____	

NOTE: This form is turned in at Klondike Registration

Klondike Sled Project

By Steven Maxwell • Illustrations by Len Churchill

Cross-country sled races deliver adventure, endurance and a wilderness challenge. And these plans are your ticket to that world. This sled is specially designed for Klondike Derby races in which boys—not dogs—provide the pulling power. Even though this sled is fast and strong, you don't have to be a master carpenter to build it. Cost of materials is about \$100.

How to Use These Directions

The instructions are divided into four parts: Building the Runners, Installing the Floor, Adding the Rails, and Finishing Up. Read everything at least once before you begin so you know how it all fits together. Then focus on each section as you work. Also, be sure to read "Prepared for Safety," which follows. What's the point in building a Klondike sled if you get hurt in the process?

Building the Runners

The runners take more punishment than any other part of the sled. That's why they need to be made of tough wood. Ash is the material of choice here—the same wood used for snowshoes and old-time cross-country skis. It's tough and flexible, and the open grain holds wax well—an important detail that'll help win races.

If you can't find ash lumber where you live, oak, maple or hickory are good, too. Just don't use pine, cedar or any wood soft enough to be dented easily by your thumbnail. These are fine for other parts of the sled, but softwood won't last long as runners or runner blocks.

When professionals build dogsleds they cook the ends of the runners for about an hour in special steam cabinets, then clamp the softened wood to

form curves when it cools. Sound complicated? It's really not. Since you need to curve only the ends of your runners, you can easily make your own steam cabinet using short lengths of galvanized duct pipe and an electric kitchen kettle. The plans show how. Make sure an adult is on hand to help you.

There's another option for runners. The plans show how to slice partway through the ends of the runners to make the wood flexible without steaming. This is called kerf bending, and it works O.K., though it does weaken the runners. They don't look as cool, either. Use this method only if nothing else is possible.

The fastest, easiest way to get your sled on the snow is to use a pair of old downhill skis as runners. Even though they're usually made of fiberglass, skis can still be drilled and fastened easily to the rest of the sled. They're tough, too.

With runners ready, it's time to drill them for the No. 12 x 2-inch screws that fasten them to the runner blocks. The plans show where each block goes and how the screws are positioned. Because they're hardwood, you'll need to create pilot holes using a $\frac{5}{32}$ -inch-diameter drill bit, to ease the entry of the screw. The plans show how to use screws as they extend through the runners to mark the runner blocks for accurate drilling. Also see "Drilling and Gluing" for more help.

Installing the Floor

At this stage, you have two separate runners with four blocks attached to the top of each one. Now it's time to join these into a single unit using the four main floor supports. Cut these to length, then drill screw holes and fasten them to the runner blocks using glue and just one No. 10 x $1\frac{3}{4}$ -inch screw per joint. Even though the front floor support is the same size as the other floor supports, leave it off for now. The plans show how the edge of the front floor support needs to be angled a bit, but that's a job for later.

Pretty easy so far, right? Don't get too confident because there's trouble lurking ahead, something that could make your sled crooked if you don't avoid it. Luckily, there's a slick trick to do just that:

With the two runners joined by the four floor supports, measure the length of diagonal distances taken from the outer corner of one floor support to the diagonally opposite corner of another. The plans show how. If your growing sled is square, then these measurements will be equal. Trouble is,

they're probably not going to be, though that's no reason to panic. Remember how you put only one screw in each joint? That lets you push and pull the runners until diagonals are equal, plus or minus $\frac{1}{8}$ inch. Once they are, the base of your sled is square. You can count on it! Now add the second

DID YOU PAY?

These plans are available on the *Boys' Life* Web site (www.boyslife.org) as an Adobe Acrobat PDF file, for downloading. Cost: \$10 per copy. Payment is on the honor system. Failure to pay - whether for a PDF file, photocopy or any other duplication of the plans - limits the magazine's ability to create other exciting, professionally-designed projects (not to mention a lifetime of guilt, and a sled doomed to last-place finishes and certain structural failure). Please remit to: Boys' Life Snow Sled Plans, P.O. Box 152079, Irving, TX 75015-2079.

screw to each joint to lock everything in place. Then fasten the floor boards with glue and screws.

The plans include a close-up view of how the front floor support, floor boards and runners come together. Take a close look at this now. You'll need to use a hand plane to angle the leading edge of the front floor support so the floor support and runners are in full contact where they meet. This is the hardest part of the project, but even this isn't a big deal. The plans show the angle to be about 35 degrees, but it will vary depending on the curvature on the ends of your runners. When all looks good, clamp the front floor support in place and drive screws through the runners into it. More screws will be added later through the sloped top rail to secure the floor boards.

Adding the Rails

The sled's rail assembly is made of 8 uprights, 2 angled tops, and a hand rail. Like everything else on the sled, these parts fit together in strong, simple ways with screws and glue. Cut the four kinds of rail uprights you'll need now—two of each type—then fasten them to the runner blocks, straight up and down, with glue and two screws per joint. The rail uprights are listed longer than necessary so you can trim along the sloped top rails with a handsaw to remove a triangular block of waste after installation. Follow the plans for the location of these parts and fasten them now. You may be tempted to trim all the rail uprights now, but don't do it. Trim only the back rail uprights so you can install the rail handle, also using

screws and glue. Leave the other rail uprights until the glue dries.

Finishing Up

Your sled's looking pretty good by now, right? But there are still a few things to take care of. The plans show the two $\frac{5}{8}$ -inch-diameter holes you'll need to drill through the floor boards, behind the front floor support, for the tow rope. You should also sand the sharp corners off the rail handle and sloped top rails, so no one gets slivers. Painting or varnishing your sled is optional. It'll look better if you do, but it is a lot of work, and it won't make the sled last any longer. Whatever you do, don't coat the underside of the runners. See "Wax Works" below for a speed-demon trail-tip.

PREPARED FOR SAFETY

Woodworking is fun—it may even become your career one day—but there's one thing you must remember. Always be careful. You must wear safety glasses when using any wood-working machinery, even if an adult is helping you. And don't forget ear protection. Earplugs or foam earplugs work fine. And if you're ever uncertain about how to use any tool, ask for help.

WAX WORKS!

You can build the best sled in the world, but it'll never win races unless you've treated the runners right. It's a make-or-break detail, and wax is the key. The best kind is cross-country ski wax—the hardest type you can find, rated for 30 degrees below zero temperatures. Rub the wax onto bare-wood runners (not varnished) when the sled's indoors, smoothing the surface with a piece of cork to get rid of the lumps. Your runners won't feel slippery after this, but that's O.K. Once they get outside, on the cold snow, they'll slide along the trail like a lightning bolt. And the guys pulling will certainly appreciate that. Just remember to let your sled cool down before setting it in the snow. Warm runners can melt snow, forming water droplets that freeze, making the runners rough and slow.

DRILLING AND GLUING

Glue and screws hold this project together, and both are easy to use if you understand a few key points. First of all, don't use ordinary white, yellow or brown carpenter's glue on this project. They're great for indoor projects but are guaranteed to turn to mush when they get wet outside. Even some brands rated as water-resistant on the label won't last long if the snow turns to slush. What you need is something called type II wood glue. It's weatherproof and available under brand names like Titebond II and Weatherite. Polyurethane glue works well outdoors, but it's more expensive. Drilling screw holes is always more accurate if you hammer a nail lightly into the wood before you bore each hole. This makes a little crater so the drill bit won't wander off the mark as the bit starts spinning. After drilling holes in the runners you'll need to flare out the bottom end with something called a countersink bit chucked into your drill. This creates a cone-shaped pocket for the screw head, so it doesn't extend below the underside of the runner and drag on the snow. Holes drilled in soft wood parts don't need to be countersunk because the screws draw themselves level with the surrounding wood.

Materials List

FOR THE RUNNER ASSEMBLIES

RUNNERS	hardwood $\frac{1}{2}$ "-thick x $3\frac{1}{2}$ "-wide x 89"-long	2
RUNNER BLOCKS	hardwood $1\frac{1}{2}$ " x $3\frac{1}{2}$ " x $3\frac{1}{2}$ "	8

FOR THE FLOOR

FLOOR BOARDS	softwood $\frac{3}{4}$ " x $3\frac{1}{4}$ " x 73"	5
MAIN FLOOR SUPPORTS	softwood $\frac{3}{4}$ " x $3\frac{1}{2}$ " x 18"	4
FRONT FLOOR SUPPORT	softwood $\frac{3}{4}$ " x $3\frac{1}{2}$ " x $19\frac{1}{2}$ "*	1

FOR THE RAIL ASSEMBLY

SLOPED TOP RAILS	softwood $\frac{3}{4}$ " x $3\frac{1}{2}$ " x 82"	2
RAIL HANDLE	softwood $\frac{3}{4}$ " x $3\frac{1}{2}$ " x $19\frac{1}{2}$ "	1
FRONT RAIL UPRIGHT	softwood $\frac{3}{4}$ " x $3\frac{1}{2}$ " x 14"	2
SHORT MIDDLE UPRIGHT	softwood $\frac{3}{4}$ " x $3\frac{1}{2}$ " x 22"	2
LONG MIDDLE UPRIGHT	softwood $\frac{3}{4}$ " x $3\frac{1}{2}$ " x 31"	2
BACK RAIL UPRIGHT	softwood $\frac{3}{4}$ " x $3\frac{1}{2}$ " x 40"	2

*Trim front edge to fit curve of your runners, about 35 degrees.

RUNNER TIP DETAIL

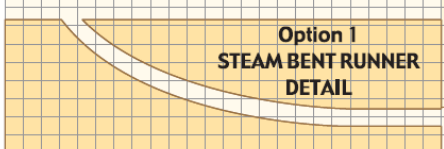

1 square = 1"

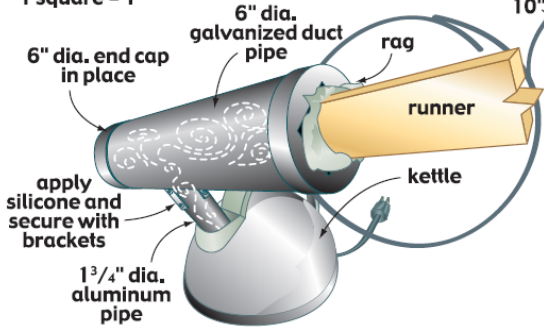

DON'T STEAM WOOD WITHOUT AN ADULT!

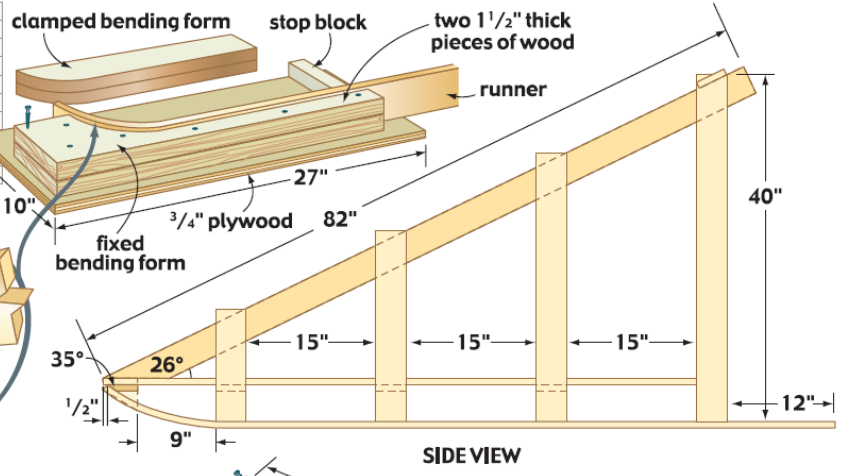
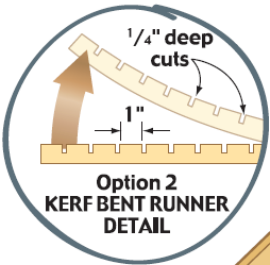

SIDE VIEW

