

Colonial District

Webelos Woods 2020

Participant Guide

January 17th-19th 2019
Camp LaNoChe

Host: Colonial District
Host Unit: Crew 911
Webelos Woods Chief: Evan Yaros

About Webelos Woods

Webelos Woods was founded in 2004 by Crew 911 Adult Advisor Don "Red" Collier in the old Fort Gatlin District. Traditionally the event has been held in the month of January every year. It is staffed by the members from Crew 911 as well as other volunteers from local Boy Scout Troops and Venture Crews in Colonial District. One of the major events of Webelos Woods is the flag retirement ceremony, conducted by Crew 911 on Saturday evening. In this ceremony the members of Crew 911 demonstrate the proper and respectful methods for retiring the American flag.

General Camp Information

- A. Webelos Units may start checking in at the registration tent and start setting up their campsites on Friday afternoon.
- B. Webelos Units will have their campsites inspected in the same manner as the Boy Scout Units' campsites.
- C. Each Den who have Patrol Flags when earn extra points for scout spirit.
- D. Awards given out will consist of Attendance, Camp Inspections, and certain competitions.
- E. The Spirit Log will be awarded to the Pack with the most scouting spirit on Sunday morning.

Scout Uniform

Scouts must wear your Field Uniform ("Class A") for:

- A. Arrival or departure from the campout
- B. Assembly for the Opening and Closing Ceremonies
- C. Religious Service

All other activities require an Activity Shirt ("Class B").

Campfire Program

Saturday night will consist of a traditional Boy Scout program featuring skits and songs. Each den can participate in the campfire and must see a staff member before 4pm on Saturday. Camp fire closing will be a flag retirement ceremony to honor those who have fallen and that are currently serving for our Country.

Registration

Webelos Woods Campout will cost **\$18.00** for youth, leaders, and guests. You will be able to download the registration form from the District Web Page. When doing so please mark the Pack number so your Pack gets credit for attending the event.

If you fail to register in the allotted time before the campout and you show up at the campout registration table, you can still register; there is a late fee.

Registration Method	Cost per person
Online/early	\$18
Regular price	\$20
Late/Walk-in	\$22
Saturday	\$22
Siblings over 4 years old	\$15

Check Out

Notify a staff member at headquarters that you are ready to leave and a staff member will visit and inspect your campsite prior to departure. Units should be ready to depart at the time of inspection. The campsite should be clean of litter and all garbage (trash cans are located along the road). After you have passed your inspection you will be given your Webelos Woods patches and you will be allowed to leave.

Friday**Schedule**

Event	Location	Time
Registration	Head Quarters (Camp Site 1)	4pm – 9pm
Cracker Barrel and movie	Head Quarters	9pm
Quiet time	Your Tents	10:30pm

Saturday

Breakfast	Your campsite	7am – 8:15am
Opening Ceremony	Open field next to HQ	8:45am
Camp site inspections		Starting at 10am
Primary events	Please refer to the included map for: <ul style="list-style-type: none"> • 1/4 Mile relay • 50 yard Dash-23 • Sit-Ups-23 • Pull-Ups-184 • Push-Ups-23 • Vertical Jump-184 • Distance Jump-23 • Noodling Race-23 • 3-man Tug-o'-War-184 • Football Distance Toss-23 • 3-Legged Race-184 • BB gun • Archery • Fire building 	9am – 12pm
Lunch	Your camp site	12pm – 1pm
Lash Box Derby check in	Fire ring	1:15pm
Lash Box Derby races	Sports Field	1:30pm – 4pm
Run-offs for all events/ Visit Troops	Sports Field	4pm
Dinner	Your camp site	5pm – 6:45pm
Dessert Judging	Deliver your dessert to HQ for judging	6pm – 6:30pm
Campfire program	Campfire Ring	7pm – 8:30pm
Quiet time	Your tents	10:30pm

Sunday

Breakfast		7am
non-denominational church service	Sports Field	8:45am – 9am
Closing ceremony	Sports Field	9am – 10am
Checkout	HQ	10am

Recognition:

Awards will be given out during the Closing Ceremony on Sunday Morning. All ribbons will be awarded for 1st, 2nd, and 3rd places to individuals in the events for youth. The Lash Box Derby will have a 1st, 2nd, and 3rd place for youth. The Best Campsite, Highest Attendance, and Best Dessert awards will be given to the respective 1st, 2nd, and 3rd place Packs for each title. Finally the Webelos Woods Spirit Log will be awarded to the pack with the most Spirit, as judged by the camp staff.

General Campsite Rules and Procedures:

All rules are to be followed in coherence with the *Guide to Safe Scouting*

Fires: All fires must be in a fire ring established by the camp. You must bring your own wood to burn.

Smoking: Smoking is not permitted at any Scouting Event.

Garbage and Litter: All garbage must be removed from your campsites before you leave on Sunday. Leave No Trace is one of the vital lessons that is learned while in Boy Scouts. A good rule of thumb: leave the area in *better* condition than when you arrived.

Vehicles in Camp: One vehicle and one trailer per Pack are allowed in the camping area. All other vehicles will need to park in the designated parking area on the main road of Camp.

Water: There are a few water spigots located throughout the camping area, we ask that you turn the water off when you are finished using them. Do not use water spigots for cleaning your pots and pans or any other kind of cooking equipment! Each pack is responsible to have a cleaning station set up in camp for this purpose.

Restrooms: The camp has hot water for showers and bathrooms for Men and Women.

First Aid: Camp LaNoChe has first aid located in Down Town camp, but all incidents need to be communicated to the Webelos Woods Chief for proper documentation.

Riding a Bike: BSA Policy states that you must wear a helmet while riding a bike. Anyone not wearing a helmet will be asked to get off the bike and walk it back to their campsite to get a helmet.

Emergency/Evacuation:

In the event of an emergency requiring an evacuation of the Camp the host unit will blow an **Air Horn**. It will consist of Three Blasts, repeated with a pause in between each set of blasts until everyone's attention is gotten. There will be no practice drills. All Webelos Dens, their leaders, parents and siblings will assemble at the Headquarters Staff Area. The Leaders will report to the Camp Chief, with their head count and report either all present or the names of any missing persons.

Please have this printed and hanging up for camp inspections:

Pack #:

Campsite:

Campsite Inspection Scorecard for Webelos Woods	5	10	n/a
Pack flag displayed properly			
American flag displayed properly			
Meal menu posted near cooking area			
Duty roster posted near cooking area			
Garbage in bags / protected from animals			
Campsite free of litter			
Cooking gear clean & properly stored			
Cooking area surfaces are clean and free of litter and personal gear.			
Drinking water is set up in campsite.			
Food securely stored from animals & according to food safety guidelines, i.e., temperature.			
First aid kit is out, clearly marked, and accessible.			
Water bucket at campsite fire ring & filled.			
Shovel left at fire ring.			
Campfire is cold-out if unattended.			
Tents are properly set up in a straight line, doors facing the campsite.			
Webelos scout-made camp gadgets: 10 points each.			
Total Points:			

Possible Points: 160, plus possible bonus points for camp gadgets.

Units scoring First, Second, and Third will earn a Campsite Ribbon

Building a Lash Box Derby Car

1. The Base of the car (Center Board) should be either a piece of the following: See illustration below.

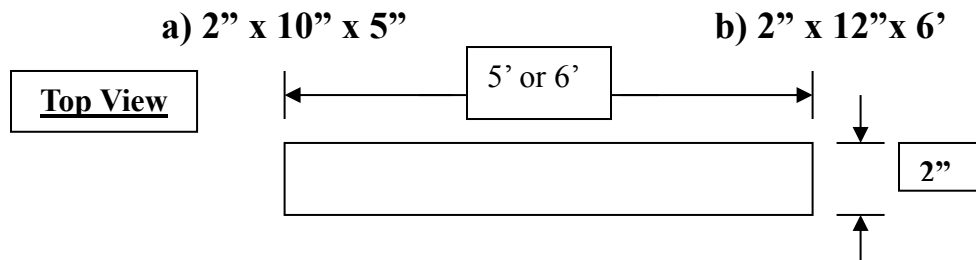

2. Front and rear axles will be made from 2 pieces of 2" x 4" x 36". 36" is the maximum length of both axles. See illustrations below.

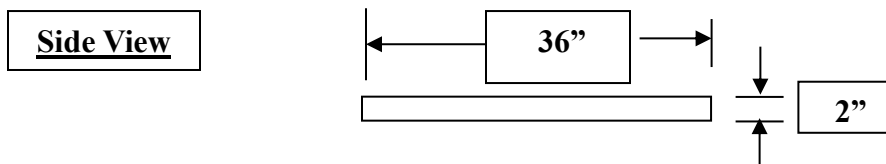

3. First locate where you want the front axle to be position on the Center Board. Then drill hole through both pieces of wood where the front axle will be installed. See illustration below.
4. Use a piece of 1/2" thin wall conduit pipe, cut it to the correct length so that when installed it will pass through the two holes that were drilled and will be flushed on top and bottom of the two pieces of wood. This conduit will be used as a sleeve so it will make the turning of the axel easy. Start by installing the piece of 1/2" conduit through the Center Board, as it starts out the bottom of the Center Board insert a large washer around the conduit, and then start it through the axel. When it is flush with the top of the Center Board and flush with the bottom of the axel, insert a 3/4" x 5" bolt and 3/4" washer from the top of the Center Board through both pieces of the wood. On the bottom of the axel where the 3/4" x 5" bolt comes through install a 3/4" washer, 3/4" locknut and 3/4" nut. See illustration below.

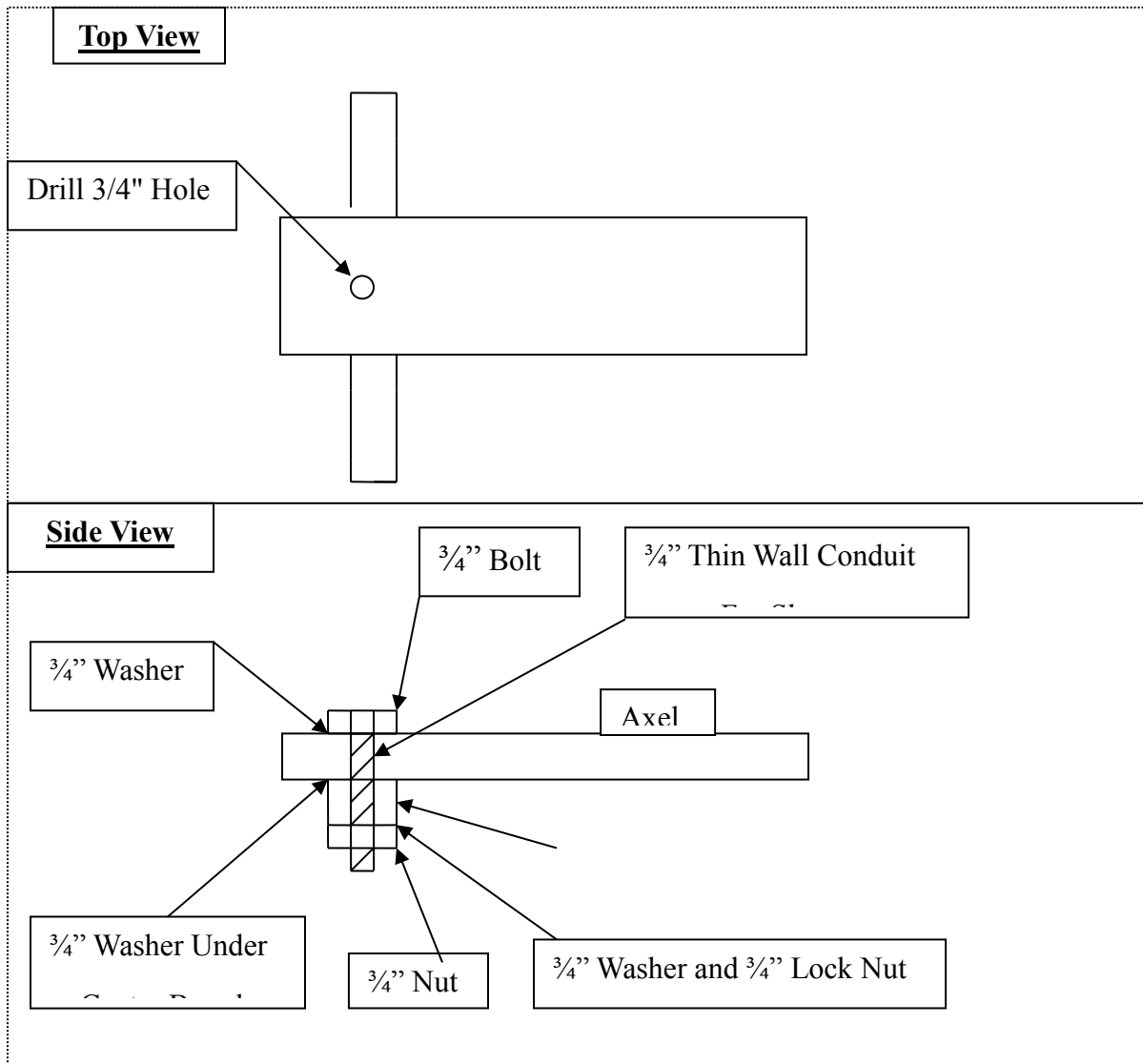

- Next locate the position on the Center Board where the rear axle will be mounted. Mark the location and drill (4) $\frac{1}{2}$ " holes where it will be attached. Use (4) $\frac{1}{2}$ " bolts, (4) $\frac{1}{2}$ " washers, (4) $\frac{1}{2}$ " lock nuts and (4) $\frac{1}{2}$ " nuts. See illustration below.

Top View

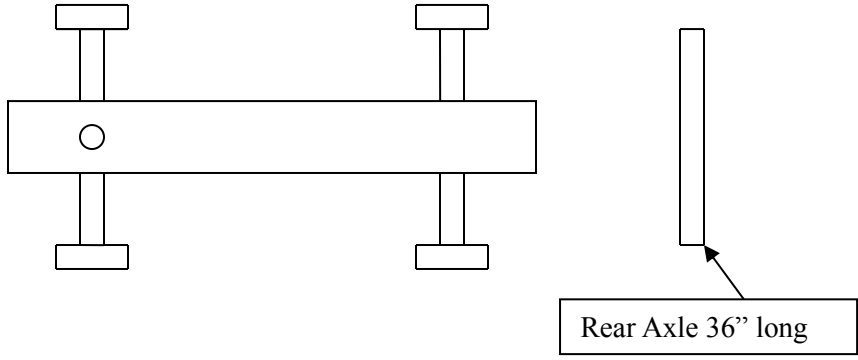

6. Wheels will be your choice. They must be firmly attached and spin freely. See illustration below.

Side View

Wheels of Your Choice

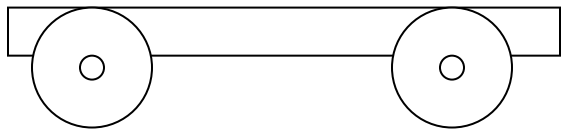

7. Next install the steering. Steering will be composed of some type of rope (**NOT CABLE**), or steering wheel assembly. If using rope it must be securely to the front axle on both sides. Next install the seat. See illustration below.

Top View

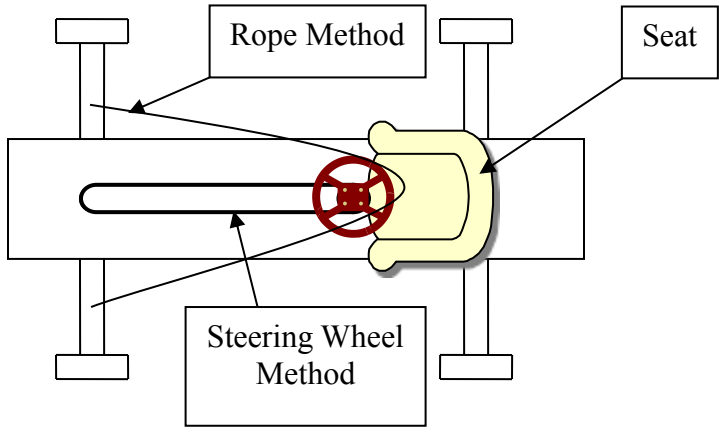

8. Now installed the driver's seat and you must make some type of a seat belt. It must be adjustable so both the Scout and others can use it for the races.

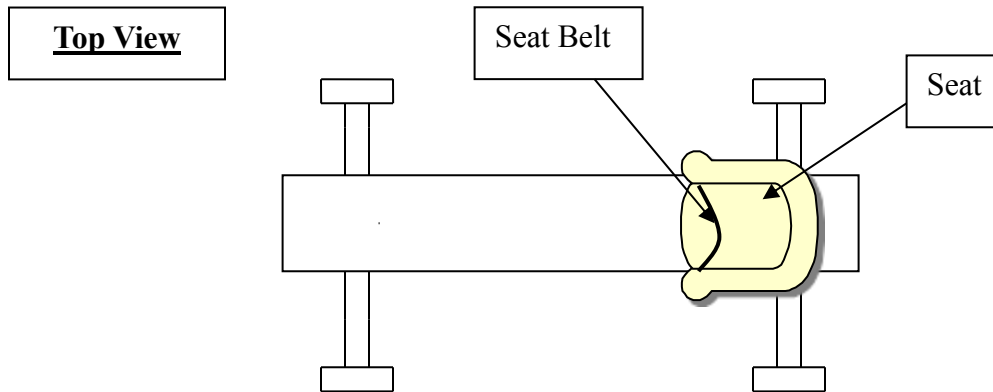

9. Next install some type of a **Hand Brake**. You may use a piece of 1" x 2" x ?" depending on how high your car sits off of the ground. You may attach the hand brake to the side of the Center Board, using a 1/2" x 4" lag screw. Next drill a 1/2" hole in the Hand Brake Handle, where it will be attached. The screw will pass through the hole and then attach to the frame. On the bottom of the hand brake attach a piece of an old tire to it so it can make contact with the ground, or you can make the brake so it rubs the rear tires when applied. If using a hand brake remember that the handle must be pulled back toward the rear of the car so that the rubber will make contact with the ground.

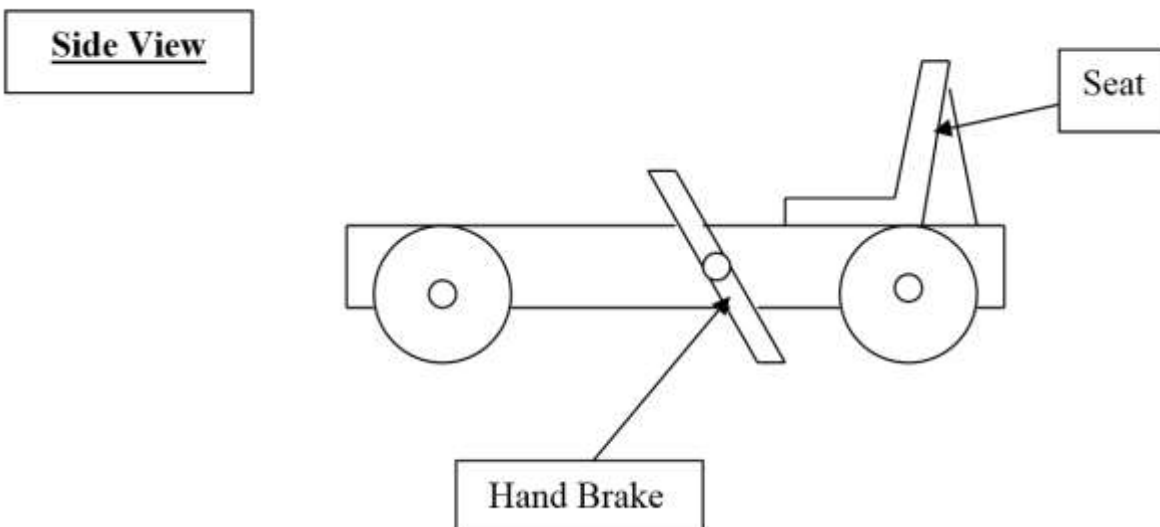

10. The Power requirements for the car are One Driver and 3 Scouts pushing. The three scouts must be pushing the car using the back push bar. See illustration below. When building the push bar, always remember that the push bar handle that the Scouts will have their hands on is NOT TO EXCEED 36" which is the width of the axels.

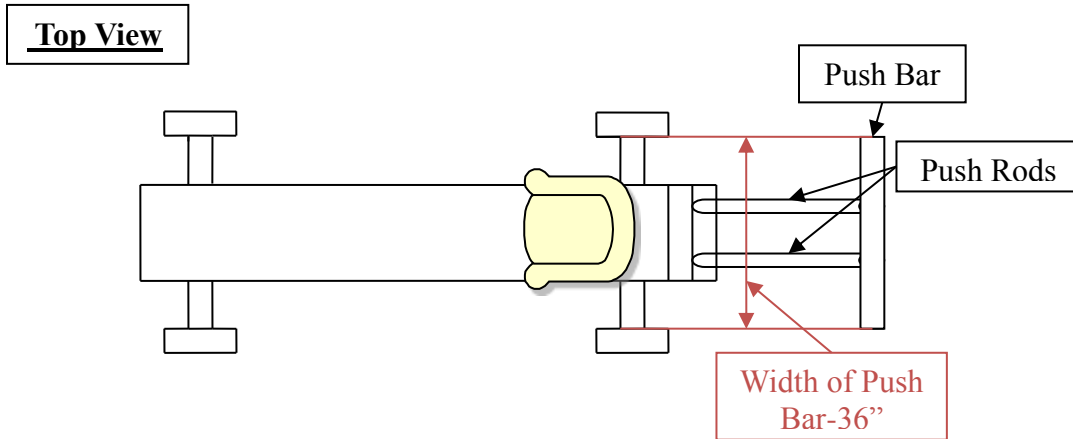

Cut 2" x 4" the width of the Center Board. Nail the first to the frame where you want to start your push-rods. Next attach the 2nd one on top of the first one. Now you can attach the push-rods to the base. Remember the Push Handle can not **exceed 36" or the width of the axel.**

Rear View

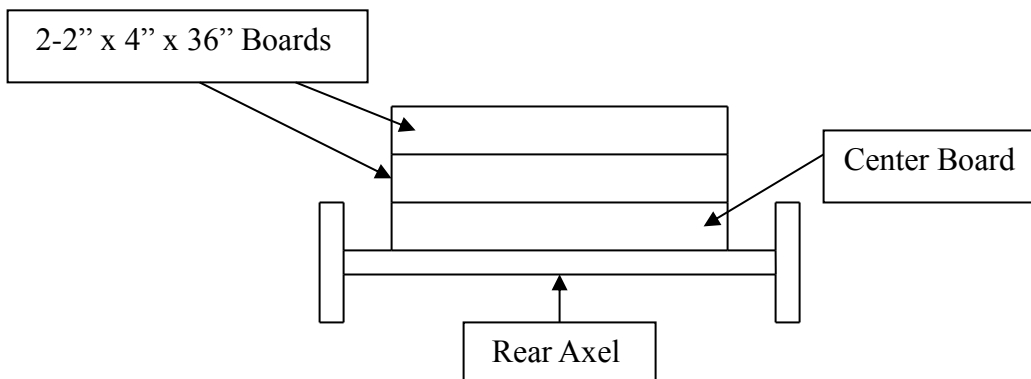

11. Make (2) Push Rods or single frame that can be placed on the rear of the Center Board. They can be permanently mounted to the frame or made removable when transporting to the campout. If making the 2-Push Rods drill a 1" hole through the 2-long 2" x 4" x "?" boards and insert a 1" dowel rod through the holes. After spacing the dowel rod between the 2-2" x 4"s drill a small hole on both sides of the dowel rod and insert some type of holding item that will keep the dowel rod from sliding back and forth during the race. If you prefer another way at the end of the 2 long 2" x 4" x "?", you can take another piece of wood and attach it across the ends of the Push Rods. Remember that the Push Handle cannot exceed 36" or the width of the axel. The axel is also 36" but it can be less.

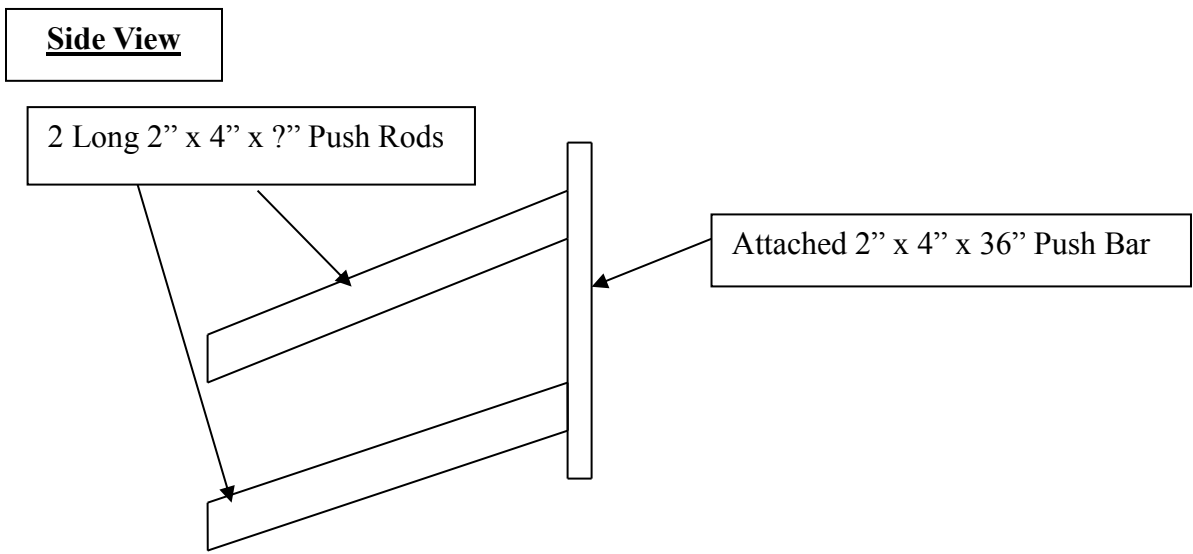
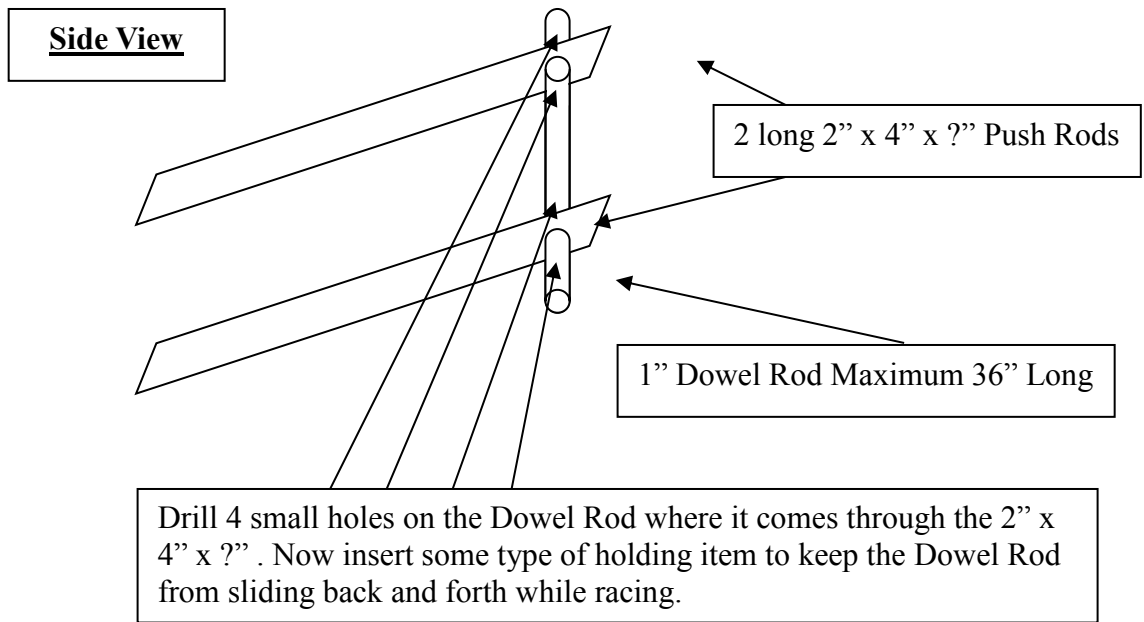

12. The pulling of the cars is prohibited during the race. This is a safety issue and will be enforced strictly.

This Should Resemble Your Lash Box Derby Race Car

Side View

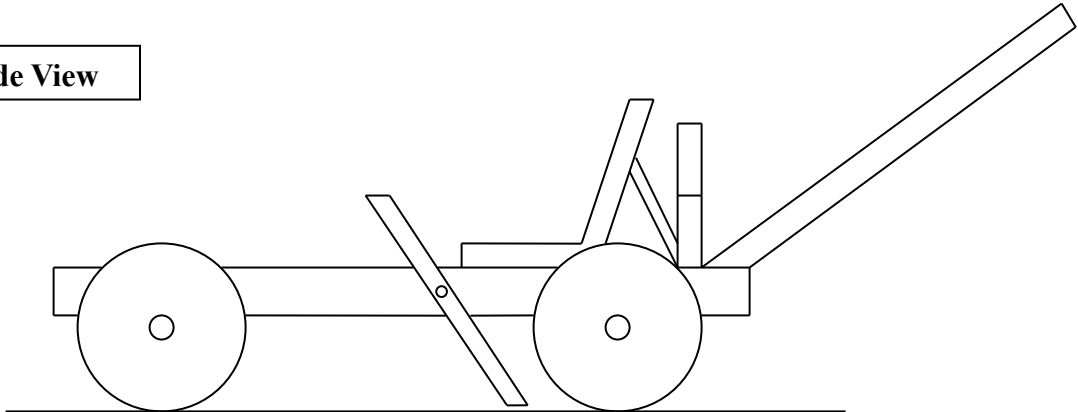

*Remember that you are pushing your car for power. The driver MUST WEAR a safety helmet at all times while sitting in the car. Helmets that can be used are motorcycle helmets, bicycle helmets, or football helmets. See illustrations below.

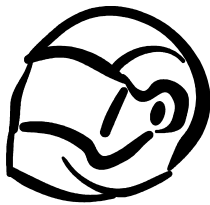

Motorcycle Helmet



Football Helmet



Bicycle Helmet

Have a Great Race

A very important message to all Scouts to remember after the races are done, shake the hands of the other drivers, as this is a sign of good Sportsmanship. There will be a 1stPlace Trophy and 2nd /3rd place winners will receive ribbons. Build your car with Pack pride, and as you paint your car put your Pack # and Patrol Name on it.

*Note to all participating, including parents and leaders of those participating, in the “Lash Box Derby”. When cheering on racers please be respectful to everyone by not being aggressive or mean, and remember this is just a fun race, so relax and have fun. In addition all results are recorded with appropriate care and are final. The winners of the “Lash Box Derby” are based on the fastest 3 times recorded after every patrol has raced twice. The winners are picked by the troop running the event and are to their discretion based on fastest times.